

# MCS 2000 Mobile Radio Service Instructions

## Volume 2g

## VHF Frequency Range, 25W Specific

# Safety Information

Every radio, when transmitting, radiates energy into the atmosphere which may, under certain conditions, cause the generation of a spark.

All users of vehicles fitted with radios should be aware of the following warnings:

Do not operate radio near flammable liquids or in the vicinity of explosive devices.

To ensure personal safety, please observe the following simple rules:

Check the laws and regulations on the use of two-way mobile radios in the areas where you drive. Always obey them. Also, when using your radio while driving, please:

- Give full attention to driving,
- Use hands-free operation, if available and
- Pull off the road and park before making or answering a call if driving conditions so require.

---

## Airbag Warning

### **VEHICLES EQUIPPED WITH AIR BAGS**

An air bag inflates with great force. DO NOT place objects, including communication equipment, in the area over the air bag or in the air bag deployment area. If the communication equipment is improperly installed and the air bag inflates, this could cause serious injury.

Installation of vehicle communication equipment should be performed by a professional installer/technician qualified in the requirements for such installations.

An air bag's size, shape and deployment area can vary by vehicle make, model and front compartment configuration (e.g., bench seat vs. bucket seats). Contact the vehicle manufacturer's corporate headquarters, if necessary, for specific air bag information for the vehicle make, model and front compartment configuration involved in your communication equipment installation.

---

## LP Gas Warning

It is mandatory that radios installed in vehicles fuelled by liquefied petroleum gas conform to the National Fire Protection Association standard NFPA 58, which applies to vehicles with a liquid propane (LP) gas container in the trunk or other sealed off space within the interior of the vehicle. The NFPA58 requires the following:

- Any space containing radio equipment shall be isolated by a seal from the

space in which the LP gas container and its fittings are located.

- Removable (outside) filling connections shall be used.
- The container space shall be vented to the outside.

---

## Anti-Lock Braking System (ABS) and Anti-Skid Braking System Precautions



### WARNING

**Disruption of the anti-skid/anti-lock braking system by the radio transmitter may result in unexpected vehicle motion.**

Motorola recommends the following radio installation precautions and vehicle braking system test procedures to ensure that the radio, when transmitting, does not interfere with operation of the vehicle braking system.

### Installation Precautions

1. Always provide as much distance as possible between braking modulator unit and radio, and between braking modulator unit and radio antenna and associated antenna transmission line. Before installing radio, determine location of braking modulator unit in vehicle. Depending on make and model of vehicle, braking modulator unit may be located in trunk, under dashboard, in engine compartment, or in some other cargo area. If you cannot determine location of braking modulator unit, refer to vehicle service manual or contact a dealer for the particular make of vehicle.
2. If braking modulator unit is located on left side of the vehicle, install radio on right side of vehicle, and conversely.
3. Route all radio wiring including antenna transmission line as far away as possible from braking modulator unit and associated braking system wiring.
4. Never activate radio transmitter while vehicle is in motion and vehicle trunk lid is open.

### Braking System Tests

The following procedure checks for the most common types of interference that may be caused to vehicle braking system by a radio transmitter.

1. Run vehicle engine at idle speed and set vehicle transmission selector to PARK. Release brake pedal completely and key radio transmitter. Verify that there are no unusual effects (visual or audible) to vehicle lights or other electrical equipment and accessories while microphone is NOT being spoken into.
2. Repeat step 1. except do so while microphone IS being spoken into.
3. Press vehicle brake pedal slightly just enough to light vehicle brake light(s). Then repeat step 1. and step 2.
4. Press the vehicle brake pedal firmly and repeat step 1. and step 2.
5. Ensure that there is a minimum of two vehicle lengths between front of vehicle and any object in vehicle's forward path. Then, set vehicle

transmission selector to DRIVE. Press brake pedal just far enough to stop vehicle motion completely. Key radio transmitter. Verify that vehicle does not start to move while microphone is NOT being spoken into.

6. Repeat step 5. except do so while microphone IS being spoken into.
7. Release brake pedal completely and accelerate vehicle to a speed between 15 and 25 miles/25 and 40 kilometers per hour. Ensure that a minimum of two vehicle lengths is maintained between front of vehicle and any object in vehicle's forward path. Have another person key radio transmitter and verify that vehicle can be braked normally to a moderate stop while microphone is NOT being spoken into.
8. Repeat step 7. except do so while microphone IS being spoken into.
9. Release brake pedal completely and accelerate vehicle to a speed of 20 miles/30 kilometers per hour. Ensure that a minimum of two vehicle lengths is maintained between front of vehicle and any object in vehicle's forward path. Have another person key radio transmitter and verify that vehicle can be braked properly to a sudden (panic) stop while microphone is NOT being spoken into.
10. Repeat step 9. except do so while microphone IS being spoken into.
11. Repeat step 9. and step 10. except use a vehicle speed of 30 miles/50 kilometers per hour.

# LIST OF EFFECTIVE PAGES

## MCS 2000 Mobile Radio Service Instructions

### Volume 2g

#### VHF Frequency Range, 25W Specific Information

#### Motorola Publication Number 68P81080C48-O

Issue Dates of Original and Revised Pages are:

Revision O: December 1998

The Number of pages in this publication is 50 consisting of the following:

<u>Page Number</u>	<u>Revision Letter</u>	<u>Page Number</u>	<u>Revision Letter</u>
Front cover	O	1 through 36	O
Inside front cover (blank)	O	Questionnaire (Front)	O
Title	O	Questionnaire (Back)	O
Safety 0 through Safety 2	O	Inside Back Cover (Replacement Parts Ordering)	C
A and B	O	Back Cover (Not Marked with Revision Letter)	O
i and ii	O		

Note: The letter O in the Revision Letter column of the table above denotes an original page. Original pages ARE NOT identified as such in the page footers except by the absence of a change letter and date.

---

IMPORTANT  
ELECTROMAGNETIC  
EMISSION  
INFORMATION

In August, 1996, The Federal Communications Commission (FCC) adopted an updated safety standard for human exposure to radio frequency electromagnetic energy emitted by FCC regulated equipment. Motorola subscribes to this same updated safety standard for the use of its products.

In keeping with sound installation practice and to maximize radiation efficiency, a one-quarter (1/4) wave length antenna should be installed at the center of the vehicle roof. If it is necessary to mount the antenna on the vehicle's trunk lid, an appropriate 3db gain antenna should be used. This installation procedure will assure that vehicle occupants will be exposed to radio frequency energy levels lower than the limits specified in the standard adopted by the FCC in General Docket 79144.

To assure that radio frequency (RF) energy exposure to bystanders external to a vehicle is lower than that recommended by FCC adopted standard, transmit with any mobile radio only when bystanders are at least two (2) feet away from a properly installed externally mounted antenna for radios with less than 50 watts of output power, or three (3) feet away for radios with 50 watts or greater power.

#### Control Station Operation

In the event of Control Station operation, to assure operators and bystanders are exposed to radio frequency (RF) energy levels lower than the limits specified in the FCC adopted standard, the antenna should be installed outside of any building, but in no instance shall the antenna be within two feet (less than 50 watts power output) or within three feet (50 watts or higher power output) of station operators or bystanders.

# Table of Contents

Safety Information . . . . .	Safety 0
List of Effective Pages . . . . .	A
Important Electromagnetic Emission Information. . . . .	B
List of Figures . . . . .	ii
List of Tables. . . . .	ii
1- Introduction. . . . .	1
2- Theory of Operation . . . . .	3
Introduction . . . . .	3
Block Diagram Level Theory of Operation. . . . .	4
Receiver Detailed Functional Description . . . . .	7
Receiver Front End . . . . .	7
Receiver Intermediate Frequency (IF). . . . .	8
Receiver Back End. . . . .	8
Transmitter Detailed Functional Description. . . . .	9
Synthesizer Detailed Functional Description. . . . .	9
Power Amplifier . . . . .	11
Overall PA . . . . .	11
PA Power Control . . . . .	13
Controller Detailed Functional Description. . . . .	14
Dc Power Control and Regulation Detailed Functional Description. . . . .	14
4 - Reference Drawings . . . . .	15

# List of Figures

Figure 1. Overall Radio Functional Block Diagram ..... 5  
Figure 2. Transceiver Board Section Locations ..... 16

# List of Tables

Table 1. Schematic Diagram Interconnection List ..... 29

Note: Reference drawings (component locations, schematic diagrams, and parts lists) are listed on page15.



# Introduction

# 1

This publication (Service Manual Volume 2g, Motorola Publication 68P81080C48) provides frequency-range-specific information for the 25-Watt MCS 2000 radio that operates in the VHF frequency range (136 to 174 MHz).

This publication is a companion volume to Service Manual Volume 1 for MCS 2000 Radios, Motorola Publication Number 68P81083C20, which provides non-frequency-range-specific information for all MCS 2000 Radios. Service personnel must have both Volume 1 and Volume 2d of this Service Manual in order to have all service information for the 25-Watt MCS 2000 Radio that operates in the VHF frequency range.

There are other Volume 2 service manuals (e.g., Volume 2b, 2c, 2d), which cover models of the MCS 2000 Radio for other frequency ranges and power levels. Refer to Volume 1 of this service manual for a list of the manuals related to operation and maintenance of all models of the MCS 2000 Radio, and the Motorola publication numbers for those manuals.

Hereafter in this manual, the MCS 2000 Radio is referred to as the radio. The specific hardware portions of the radio covered in this volume of the service manual are as follows:

- Receiver Front End
- Receiver Intermediate Frequency (IF)
- Receiver Back End
- Power Amplifier
- Synthesizer

This volume (Volume 2g) of the service manual covers the following four topics for the specific hardware portions of the VHF radio:

- Theory of operation
- Component locations
- Parts lists
- Schematic diagrams and associated interconnect information

The four topics listed above for the controller section and for the control heads are covered in Volume 1 of this service manual, Motorola Publication Number 68P81083C20.

All the radios covered in this service manual contain a single circuit card assembly (a printed circuit board with components mounted), which is called the transceiver board.

# Theory of Operation

## 2

This chapter provides theory of operation information for the radio. It starts with a block diagram level functional description of the entire radio. This is followed by a detailed functional description for each of the four major functions of the radio.

---

### Introduction

The radio is composed of the following five major functions:

- Receiver
- Transmitter
- Controller
- Dc Power Control and Regulation
- Operator Interface (Control Head)

The receiver, transmitter, controller, and dc power control and regulation functions are all located on a single circuit card assembly (CCA) in the main body of the radio. The CCA is called the transceiver board. The operator interface function consists of the control head, which plugs into the main body of the radio. There are three different control head types: the Model I for the Model I Radio; the Model II for the Model II Radio; and the Model III for the Model III Radio. The three control heads are covered in their entirety in Volume 1 of this service manual.

The transceiver board in the main body of the radio is physically separated into six functional sections as follows:

- Receiver Front End
- Receiver Intermediate Frequency (IF)
- Receiver Back End
- Power Amplifier (PA)
- Synthesizer
- Controller

The controller section is further divided into two sub-sections: main controller; and power control.

The mechanical layout of the transceiver board is illustrated in Chapter 3.

Separate component location diagrams, parts lists, and schematic diagrams are provided in this service manual for each of the six physical sections of the transceiver board and for the control heads. The component location diagrams, parts lists, and schematic diagrams for the controller section of the transceiver board and for the three types of control heads are located in Volume 1 of this service manual. The component location diagrams, parts lists, and schematic diagrams for the other five physical sections of the transceiver board are located in this volume.

---

## Block Diagram Level Theory of Operation

The following discussion refers to the functional block diagram for the radio, Figure 1.

The receiver function of the radio detects, demodulates, amplifies, and outputs via the loudspeaker, radio signals picked up by the vehicle or fixed-station antenna. The radio signal input reaches the receiver from the antenna via the antenna switch, which is located in the transmitter function of the radio. The radio signals picked up by the antenna are signals that have been re-broadcast by trunked or conventional repeaters, or that have been broadcast directly by other mobile or fixed station radios.

The receiver function of the radio consists of: the receiver front end section; the receiver intermediate frequency (IF) section; the receiver back end section; and the audio signal filter (ASFIC) and receiver audio power amplifier circuits in the controller section.

The receiver function of the radio uses the double conversion super-heterodyne design to optimize image rejection and selectivity. The receiver front end section converts the receiver input signal to a first IF of 44.85 MHz. The frequency upon which the receiver operates is determined by a first local oscillator signal generated by the synthesizer section. For the purpose of this discussion, the synthesizer section is considered to be part of the transmitter function of the radio.

The 44.85 MHz IF output signal from the receiver front end section passes through the receiver IF section where it is filtered and amplified. The output of the receiver IF section goes to the receiver back end section. In the receiver back end section, which contains the zero intermediate frequency (ZIF) integrated circuit (IC), the receiver IF signal is demodulated to produce receiver audio and squelch signals.

The receiver audio and squelch signal outputs from the receiver back end section are processed by the audio signal filter integrated circuit (ASFIC) in the controller section of the radio to generate receiver audio (filtered) and squelch detect signals. The filtering characteristics and other processes of the ASFIC are controlled by the central processor unit in the controller section.

The receiver audio signal (filtered) from the output of the ASFIC goes to the input of the receiver audio power amplifier circuit, which is located in the controller section of the radio.

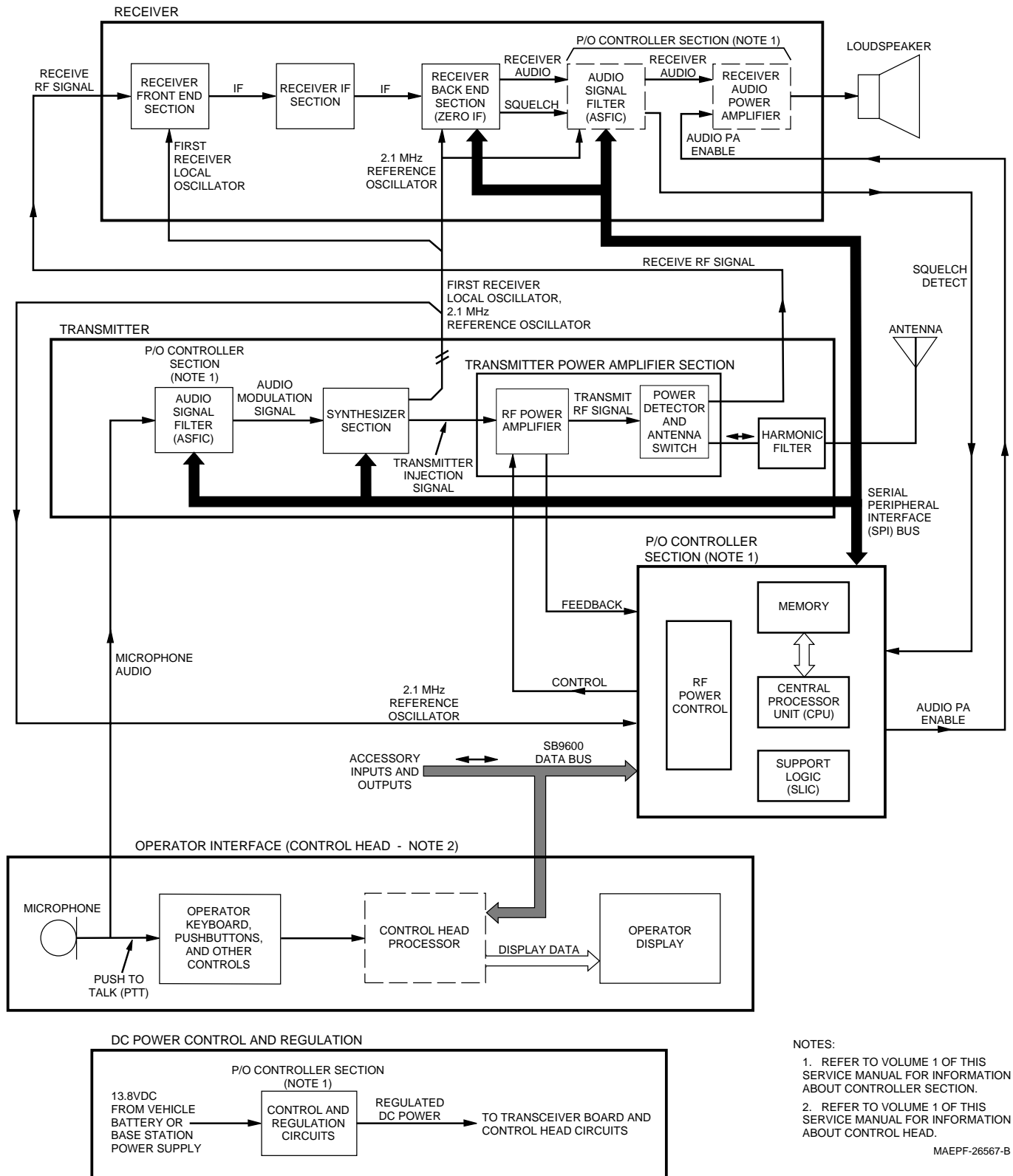

Figure 1 . Overall Radio Functional Block Diagram

The receiver audio power amplifier circuit does not pass the receiver audio signal to the loudspeaker until it receives an audio PA enable signal from the controller section of the radio. The reason is that the receiver portion of the radio includes a squelch function, which prevents receiver noise from passing to the loudspeaker during periods of no signal reception. The controller generates the audio PA enable signal based on such variables as the level of the received signal, the frequency channel, and the operating mode of the radio. When the audio PA enable signal is generated, the audio power amplifier (PA) is activated and passes the receiver audio signal to the loudspeaker.

The transmitter function of the radio produces a nominal 25-Watt radio frequency output signal. The radio frequency output signal is frequency modulated by an audio signal from the microphone or from another source such as a telephone keypad or handset.

The transmitter function of the radio consists of: the audio signalling filter integrated circuit (ASFIC) in the controller section; the synthesizer section; and the transmitter power amplifier (PA) section. The ASFIC develops a modulation signal by amplifying an audio signal from the microphone, keypad, or handset. The synthesizer section generates a radio frequency carrier signal upon which the transmitter portion of the radio operates. The radio frequency carrier signal generated by the synthesizer section is frequency modulated in the synthesizer section by the modulation signal output from the ASFIC.

The frequency modulated output signal from the synthesizer section is amplified to the required nominal 25-Watt power level by the power amplifier (PA) section. The output of the PA section passes through the antenna switch and is radiated by the vehicle antenna or fixed-station antenna.

The controller section of the radio contains a microprocessor that controls the radio in accordance with its built in programming as well as commands input manually by the radio operator. The radio operator inputs manual commands to the controller section using the pushbuttons and other controls located on the control head. In addition to its controlling functions, the controller section provides audio amplification of the audio output signal in the receiver function. It also contains squelch detect circuitry based on a buffered discriminator signal from the Zero Intermediate Frequency Integrated Circuit (ZIF IC).

The operator interface function of the radio consists of: a microphone or the microphone portion of a telephone handset; a telephone keypad if used; the pushbuttons and other controls on the control head; and the digital and graphics displays on the control head. The pushbuttons and other controls on the control head provide digital commands to the controller section, and in some instances, hardwired commands to controlled circuits. The digital and graphics displays receive display data from the controller section. The control head contains its own microprocessor, which communicates with the controller section of the radio via an SB9600 serial digital data bus.

The DC power control and regulation function regulates and distributes to the various sections of the radio, DC power from the vehicle battery or fixed station power supply.

---

## Receiver Detailed Functional Description

The portion of the receiver function that is not part of the controller section of the radio is composed of three main sections: receiver front end; receiver intermediate frequency (IF), and receiver back end. The receiver covers the VHF range from 136 to 174 MHz.

### Receiver Front End

The following discussion is based on the schematic diagram for the receiver front end section on page 19.

### Varactor Tuned Band-pass Filter

A two pole filter tuned by dual varactor diode CR3302 preselects the incoming receive signal at terminal IF10-3-1 to reduce spurious effects to the stages that follow. The filter tuning voltage at terminal IF1-3-6, which ranges from 2.5 VDC to 7.5 VDC, is controlled by a digital to analog (D/A) converter integrated circuit in the controller section of the radio. The filter has three bandstops: at approximately at 45 MHz for the first IF; at 95 MHz for broadcast frequencies; and at the receive frequency plus 50 MHz for the receiver local oscillator frequency. The three bandstops improve receiver performance at those three specific spurious signal frequencies.

In transmit mode, the input signal to the receiver front end is reduced by PIN diode CR3330, which is part of the RX/TX switch in the power amplifier section of the radio. A dual hot carrier diode (CR3303) limits any in-band signal to 10 dBm to prevent damage to the receiver preamplifier.

### Preamplifier

The receiver preamplifier (Q3302) is a surface mount device (SMD), which has emitter and collector base feedback to stabilize gain and impedance, and minimize intermodulation distortion. To provide optimum transistor current drain, Q3302 is actively biased by a collector current sense circuit (Q3301 and associated components), which in receive mode is also used to bias the receive series PIN diode CR3641 (in the power amplifier section) via the decoupled emitter path of Q3302.

The Q3302 collector current is set to approximately 22 mA at an emitter voltage of about 2 volts. The combined preamplifier and PIN diode bias circuit is driven by the keyed 9-Volt line (K9V1) from the controller section of the radio.

To stabilize its output impedance, the preamplifier is followed by a 3 dB pad.

### Fixed Tuned Band-pass Filter

A five pole fixed tuned band-pass filter, with two bandstops (both at approximately 220 MHz to suppress image frequencies), is included after the preamplifier. The filter provides signal transmission over the VHF range, wideband spurious signal suppression, and preamplifier to mixer matching.

### Mixer

Q3303 is a double balanced active Gallium Arsenide (GaAs) mixer. Its three ports are matched for incoming VHF signal conversion to the 44.85 MHz IF using high-side injection. The mixer bias is set by R3341 to approximately 24 mA with  $P_{inj}$  (RX INJ) = 5 dBm.

The mixer IF output signal is fed through transformer T3303, where its impedance is transformed to match the input impedance of the receiver IF section.

Receiver Intermediate Frequency (IF)	The following discussion is based on the schematic diagram for the receiver IF section on page 21.
Intermediate Frequency (IF) First Selection	To optimize half-IF stability, a diplexer shunt circuit (C3401, R3401, L3401, C3402) matches the output impedance of the mixer in the receiver front end section to the input of two pole crystal filter Y3401 at the input of the receiver IF section. The output of filter Y3401 is matched to the following IF amplifier (Q3401).
IF Amplifier	IF amplifier Q3401 is a surface mount device of the same type as preamplifier Q3302 in the receiver front end section. It is actively biased by a collector base feedback circuit to a current drain of approximately 10 mA. Its output voltage swing is limited by a dual hot carrier diode (CR3402) to reduce overdrive effects at RF input signal levels above 27 dBm.
IF second selection	<p>IF amplifier Q3401 is followed by matching networks into and out of the second crystal filter (Y3402). To optimize the filter pass band, a certain amount of signal is coupled from the input to the output of the filter to achieve a notch at the higher and lower adjacent channel. This improves the adjacent channel selectivity.</p> <p>The output from filter Y3402 is coupled via capacitor C3411 and terminal 1F3-2-9 to the input of the receiver back end section.</p>
Receiver Back End	The following discussion is based on the schematic diagram for the receiver back end section on page 23.
Zero IF (ZIF) Isolation Amplifier	To obtain proper operation of the ZIF IC (U3201) in the receiver back end section, an isolation amplifier (Q3203) combined with an IF automatic gain control (AGC) and a low-pass filter follows. The collector path of Q3203 is loaded with a PIN diode (CR3203) in shunt configuration. Its control voltage is generated by a bias circuit with CR3204 in conjunction with the voltage out of U3201 pin 4 (U3201-4). This configuration provides a maximum AGC dynamic range of 40 dB and isolates the sensitive ZIF IC from an overdriving IF level. Additionally, the signal is low-pass filtered to suppress non-linear effects within the ZIF IC.
ZIF IC (U3201)	<p>Within the ZIF IC, the 44.85 MHz IF signal is mixed in two quadrature paths down to baseband, filtered, processed, and FM demodulated. The conversion process to baseband is performed by using a second LO circuit consisting of Q3201, inductor L3204 and several capacitors that, in combination with varactor diode CR3201 and a loop filtered steering line from U3201-18, closes a phase locked loop (PLL).</p> <p>The demodulated audio signal exits the ZIF IC at U3201-28 and is applied to the Audio Signalling Filter IC (ASFIC), which is located in the controller section of the radio.</p>



---

## Transmitter Detailed Functional Description

The transmitter function of the radio is distributed between the controller, synthesizer, and power amplifier (PA) sections of the radio. This is shown on the overall functional block diagram for the radio, Figure 1.

The portion of the transmitter function physically located in the controller section is described in the *Controller Section Theory of Operation* located in Volume 1 of this service manual. That portion includes the audio circuits that filter, amplify, and otherwise process the audio signal from the microphone and/or telephone handset.

The portion of the transmitter function located in the synthesizer section of the radio is described in the *Synthesizer Detailed Functional Description*, which follows this paragraph.

The remaining part of the transmitter function of the radio is located in the power amplifier section, which is described after the description of the synthesizer.

## Synthesizer Detailed Functional Description

The synthesizer section of the transmitter receives the amplified and processed audio signal from the controller section of the radio and produces a frequency-modulated radio frequency carrier signal (the transmitter injection signal), which is input to the transmitter power amplifier (PA) section.

The synthesizer section of the radio also generates the first conversion local oscillator signal (180.85 to 218.85 MHz) and the second conversion reference oscillator signal (2.1 Mhz) for the receiver and controller sections of the radio.

The following discussion is based on the schematic diagram for the synthesizer section on page 25.

## Synthesizer Circuitry

The synthesizer consists of Pendulum reference oscillator U5800, Fractional-N integrated circuit (IC) U5801, transmit and receive voltage controlled oscillators (VCOs) Q3803 and Q3804, buffer amplifiers Q3805 and Q5801, transmit injection amplifier Q5802, and feedback amplifier Q5774.

Pendulum reference oscillator U5800 contains a temperature compensated quartz crystal oscillator with a frequency of 16.8 MHz. The oscillator is tuned by a temperature referenced 5-bit analog-to-digital (A/D) converter located in the controller section of the radio. The output of the oscillator (U5800-10) is applied to U5801-14 (XTAL1) via C5754 and R5750.

The transmit and receive VCOs are the grounded drain Colpitts type using junction field effect transistors (JFETs) and lumped elements. The transmit VCO covers the frequency range of 136 to 174 MHz. The receive VCO covers the range of 180.85 to 218.85 MHz. The transmit VCO is activated by U5801-38 (AUX2) and the action of transistor switches Q3806 and Q3802. The receive VCO is activated by U5801-39 (AUX3) and the action of transistor switches Q3807 and Q3801. The frequency of each VCO is proportional to the applied control voltage, which is in the range of 2 to 11 VDC. The control voltage is applied to frequency control varactors CR3803 through CR3806 via a loop filter.

The Fractional-N synthesizer Integrated Circuit (U5801) contains the following circuits:

- Prescaler
- Programmable loop divider
- Control divider logic
- Phase detector
- Charge pump
- A/D converter for low frequency modulation
- Modulation low-frequency/high-frequency balance attenuator
- Positive voltage multiplier drivers
- Serial interface for control
- Super filter low noise supply

Transistor Q5770 is a current amplifier for the super filter low noise supply. The super filter drops 9.3 VDC (emitter of Q5770) to about 8.6 VDC (collector of Q5770). The filtered 8.6 VDC supplies the oscillator circuit, modulation circuit, VCO switching circuits, and synthesizer charge pump resistor network. Feedback amplifier Q5774 provides the amplification and isolation necessary to drive the prescaler input (U5801-21). Three-terminal regulator U5802 drops 9.3 VDC from the controller section of the radio to 5 VDC required by the Fractional-N synthesizer IC.

To generate a high voltage needed by the phase detector (charge pump) output stage at U5801-36 (VCP), a voltage of 13 VDC at CR5750-1 is generated by a positive voltage multiplier (CR5750, C5759, C5760). The positive voltage multiplier is basically a diode capacitor network driven by two 1.05-MHz 180 degrees out of phase signals (U5801-8 and U5801-9).

The serial interface (SRL) of the microprocessor in the controller section of the radio is connected to the data line (U5801-2), clock line (U5801-3), and chip enable line (U5801-4) of the fractional-N IC.

## Synthesizer Operation

The complete synthesizer works as follows: Fractional-N IC U5801 is programmed for either transmit or receive via the serial data bus. The appropriate VCO is activated via the AUX control pins of U5801 and the prescaler and loop divider are set for the desired frequency. The outputs from the VCOs are amplified by buffer amplifiers Q3805 and Q5801. The output of buffer amplifier Q5801 is split three ways. First, the feedback amplifier Q5774 is connected via the resistive attenuator consisting of R5773, R5771, and R5772. The local oscillator port for the mixer in the receiver front end section of the radio is also connected at this node (Rx Inj). Finally, transmit injection amplifier Q5802 is connected at this node via the resistive attenuator composed of R5782, R5783, and R5784. The output of amplifier Q5802 (TX inj) is connected to the transmitter power amplifier.

The prescaler in the synthesizer (Fractional-N IC U5801) is basically a dual modulus prescaler with selectable divider ratios. The divider ratio of the prescaler is controlled by a loop divider, which in turn receives its inputs via the SRL. The output of the prescaler is applied to the loop divider. The output of the loop divider is connected to the phase detector, which compares the loop divider output signal with a reference signal. The reference signal is generated by dividing down the signal of the reference oscillator (Pendulum oscillator U5800). The

output signal of the phase detector is a pulsed DC signal, which is routed to the charge pump. The charge pump outputs a current at U5801-32 (I OUT). The loop filter (which consists of R5760 through R5762 and C5775 through C5780) transforms this current into a voltage, which is applied to both VCOs to control their output frequencies.

The current can be set to a value fixed in the FRACN IC or to a value determined by the currents flowing into CPBIAS 1 (U5801-29) or CPBIAS 2 (U5801-28). The currents are set by the values of R5752 and R5753 or R5756 and R5757, respectively. Selection of one of the three different bias sources is done by the radio software.

To reduce synthesizer lock time when new frequency data has been loaded into the synthesizer, the magnitude of the loop current is increased by enabling the I ADAPT line (U5801-34) for a certain software-controlled amount of time (Adapt Mode). Additionally the loop current is increased by bypassing R5752 and R5753 with Q5750, and bypassing R5756 and R5757 with Q5751. Bypassing starts when the FRACN CE line changes from high to low and ends a certain delay time after the transition from low back to high. The adapt mode timer and the bypassing delay are both started by the low to high transition of the FRACN CE line. The adapt mode time is programmed to be somewhat shorter than the bypassing delay time, which is hardware dependent. This causes two different current levels during frequency acquisition of the loop. When the synthesizer is within the lock range, the current is determined only by the resistors connected to CPBIAS 1, CPBIAS 2, or the internal current source.

The output of the balance attenuator is MODOUT (U5801-30) and is connected to the transmit VCO modulation network. The modulation is applied to the transmit VCO via varactor diode CR3807.

Transmit Injection Amplifier

Transmit injection amplifier Q5802 increases the output of Q5801 to about +13 dBm. This is the level required by the first stage of the transmitter power amplifier. The transmit injection amplifier collector supply of 9.1 volts and originates in the controller section of the radio. It is active only during transmit.

Power Amplifier

Overall PA

The power amplifier (PA) is a radio frequency (rf) power amplifier, which amplifies the output from the injection string (TX\_INJ) to an RF output power level of 25 Watts.

The following discussion is based on the schematic diagram for the power amplifier (PA), on page 27

The PA is a three stage amplifier, which amplifies the output from the transmitter injection string in the Synthesizer Section to the transmit level (nominally 25 Watts).

The first stage (Q3521) of the PA is a bipolar stage, which is controlled via the PA control line. It is followed by two Metal Oxide Semiconductor Field Effect Transistor (MOSFET) devices, Q3541 and Q3561.

Devices Q3521 and Q3541 are surface mounted. To remove heat from Q3541, the surface mounted heat spreader on the opposite side of the

printed circuit board provides thermal contact of the transistor to the heat sink on the radio chassis. Transistor Q3561 is attached directly to the heat sink.

The RF power output of Q3521 is proportional to the Q3521 collector current. This current is adjusted by the PA control voltage (PA Control). If the PA control voltage raises, the base voltage of Q3601 is also raised, which causes more current to flow to the collector of Q3601 and a higher voltage drop across R3606. This results in more current being drawn by Q3501 so that the base current on Q3521 is increased. This in turn causes higher collector current to flow through Q3521. The collector current settles when the voltage drop across the parallel combination of resistors R3530 through R3533 equals the voltage drop across R3606 minus the base-to-emitter voltage drop of Q3501.

By controlling the output power of Q3521 and in turn the input power of the following stages, the automatic level control (ALC) loop is able to regulate the output power of the transmitter.

The MOSFET devices Q3541 and Q3561 are enhancement mode N-Channel MOSFETS. For proper operation, these devices require a positive gate bias voltage and a quiescent current flow with no drive. To achieve these requirements, the gates are biased through the network consisting of R3582, R3525, and R3526 for Q3541 and similarly R3585, R3544, and R3545 for Q3561. The actual value of the voltage at this gate is device dependent and determined by trim in the factory when the radio is built.

The output of Q3561 goes through the matching network consisting of four transmission lines, inductor L3566, and several capacitors to the directional coupler.

Directional Coupler, RX-TX  
Switch, and  
Harmonic Filter

The forward power detector (directional coupler) is a microstrip printed circuit, which couples a small amount of the forward RF energy off and sends it to diode CR3671 where it is rectified. The rectified signal forms the V detect voltage, which is proportional to the rectified RF energy appearing across the diode. The power control circuit holds this voltage constant, thus ensuring that the forward power out of the radio is held constant.

The antenna switch is switched synchronously with the keyed 9.1 voltage (K 9V1). In transmit mode, the K 9V1 line is high and the current turns on the PIN diode CR3641. The receiver preamplifier transistor Q3302, also turned off by the keyed 9.1 voltage, cuts off the current through the PIN diode CR3642 and turns off transistor Q3641.

In receive mode the K 9V1 line is low. This turns off the PIN diode CR3641 and turns on the receiver preamp transistor Q3302. The current through Q3302 turns on the PIN diode CR3642 and transistor Q3641. Q3641 shorts R3644 to increase the current through Q3302.

Harmonics of the transmitter are attenuated by the harmonic filter formed by inductors L3661 through L3663, and capacitors C3661 through C3664. This network forms a low-pass filter to attenuate harmonic energy of the transmitter to an acceptable level. L3664 provides electrostatic protection for the power amplifier.

Temperature Sense

In the PA compartment, 100K ohm thermistor R3610 senses the temperature of MOSFET devices Q3541 and Q3561. This signal is fed back into the power control circuit to protect the power amplifier

against over temperature conditions. The power control circuit senses the voltage drop across shunt resistor R3615, which is determined by the magnitude of the drain current in Q3561. This is a limit mechanism whereby the power control limits the magnitude of current that can be drawn by Q3561 to protect the device from excessive power dissipation.

## PA Power Control

The maximum value of the PA control line is limited by R3601 and R3602, the resistor divider off of PA control. This inputs a signal back into the power control circuit that limits the magnitude of the voltage to which the PA control line can rise.

Reverse polarity protection for the transmitter is provided by diode CR3601. This diode is soldered to the board as well as being pressed against a member in the chassis heat sink so under reverse polarity conditions to the radio this diode conducts and protects the radio from damage. This diode also provides transient over-voltage protection by breaking down when the supply voltage to the radio exceeds 25 volts.

The power control circuit (located in the controller section of the radio) consists of the control amplifier (U0550-9), the control voltage limiter (U0202), the detector voltage buffer/amplifier (U0550-12, -13, -14) the PA temperature sense circuit (U0550-1, -2, -3) and the current limit circuit.

The voltage from the forward power detector in the PA is amplified by U0550-12, -13, -14. The output voltage is added to the PA power set voltage at the inverting input of control amplifier U0550-9. Its noninverting input is set to a fixed 4.65 volts. As long as there is a differential input voltage at the control amplifier input, the output voltage (PA control voltage) is altered. This in turn causes a change of the RF output power level and the detector voltage, which leads to a changing differential input voltage. When the control loop is in steady state the voltages at both the inverting and the noninverting input are equal.

To obtain a higher RF output level, the power set voltage generated by the D/A converter U0551-2 is reduced. This causes a lower level at the summing point U0550-9. The control loop compensates this difference by increasing RF power and detector voltage until balance between the two control amplifier inputs is obtained again. Reduction of the power level works in the opposite manner.

Operational amplifier U0202 functions as an integrator, which controls, via Q0556, the control voltage slope during key up and dekey.

During RX operation, Q0556 pulls R0590 down, the output of U0202 is at its maximum level, Q0555 conducts and the output of U0550 is at its minimum output level.

After pressing PTT, transistor Q0556 switches off. Capacitor C0552 is charged via R0584 and R0590. In turn the output voltage of U0202 decreases which causes an increase of the voltage at the non-inverting input of U550. This increases the PA control voltage. The loop is closed via R0591 and R0592. This feedback causes an exponential like rising edge of the control voltage. Such a smoothed keyup leads to an improved adjacent channel power reduction during TX keyup compared with a linear ramp.

After keyup the circuit does not effect the performance of the power control circuit as long as the control voltage does not increase over a certain value defined by R0591/R0592 and the voltage applied to R0584 by the D/A output U0055-13. If this occurs the control voltage will be limited to the predefined value and the PA prevented from being damaged.

If the radio switches from TX to RX transistor Q0556 pulls R0590 down and C0552 is discharged via R0590. This causes the output of U0202 to go up and tie down the noninverting input of U0550. The control voltage decreases controlled by the loop U0202, Q0555, and U0550.

The protection features in the PA power control operate by raising the non-inverted input to the operational amplifier above the reference voltage, which has the same effect as a larger input from the coupler. The thermal shutback circuit works when the temperature of R3610 decreases its resistance, the output at pin 1 of U0550 increases. When that voltage rises above the reference voltage at pin 10 of U0550, the control voltage of the PA is decreased lowering the power output. The current limiting circuit measures the voltage drop across R3615 causing an adjustable offset to the voltage controlled by the D to A output for current limit set. The difference of that is amplified at pin 7 of U0550. When the voltage exceeds the reference at pin 10 of U0550, then current limit starts to engage reducing power output.

---

## Controller Detailed Functional Description

The theory of operation for the controller section of the radio is located in Volume 1 of this service manual.

---

## DC Power Control and Regulation Detailed Functional Description

The theory of operation for the dc power control and regulation section of the radio is located in Volume 1 of this service manual.

# Reference Drawings

# 3

This section contains the reference drawings listed below for the receiver (front end, IF, and back end), transmitter, and synthesizer portions of the radio.

- **Overall Radio:**

- Transceiver Board Section Locations - Page 16
- Schematic Diagram Interconnection List, Table 2 - Page 29

- **Receiver:**

- Receiver Front End Component Locations and Parts List - Page 18
- Receiver Front End Schematic Diagram - Page 19
- Receiver IF Component Locations and Parts List - Page 20
- Receiver IF Schematic Diagram - Page 21
- Receiver Back End Component Locations and Parts List - Page 22
- Receiver Back End Schematic Diagram - Page 23

- **Synthesizer:**

- Synthesizer Component Locations and Parts List - Page 24
- Synthesizer Schematic Diagram - Page 25

- **Power Amplifier:**

- Power Amplifier Component Locations and Parts List - Page 26
- Power Amplifier Schematic Diagram - Page 27

Refer to Volume 1 of this service manual (Motorola Publication 68P81083C20) for reference drawings for the controller and control head portions of the radio.

Refer to the Secure Option service manual (Motorola Publication 68P81083C25) for reference drawings for the secure option for the radio.

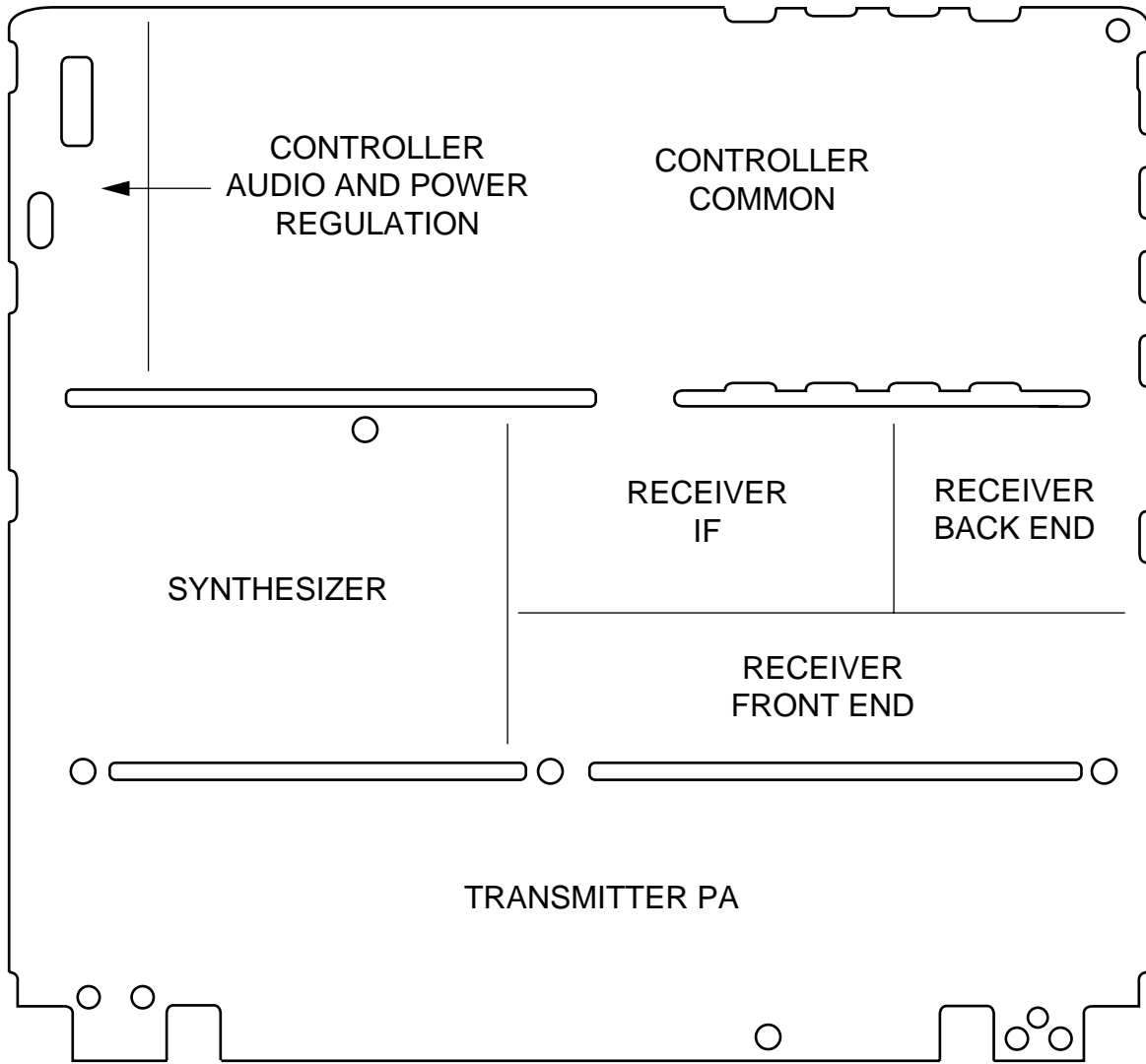

MAEPF-26504-O

*Figure 2 Transceiver Board Section Locations*



# NOTES

# RECEIVER FRONT END COMPONENT LOCATIONS

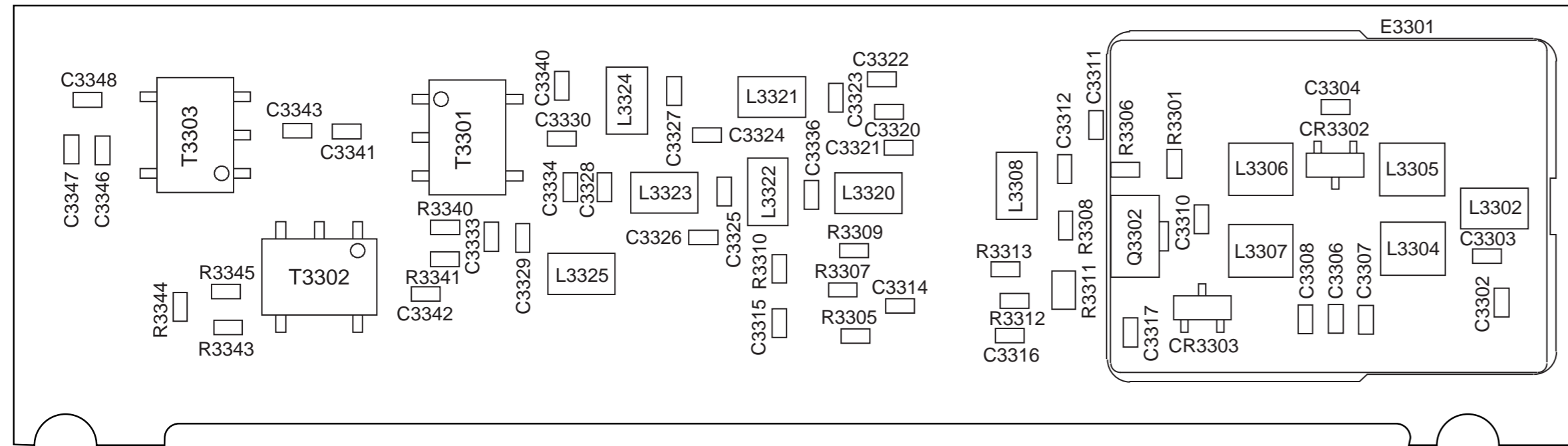

HEAVY COMPONENTS SIDE

MAEPF-26494-O

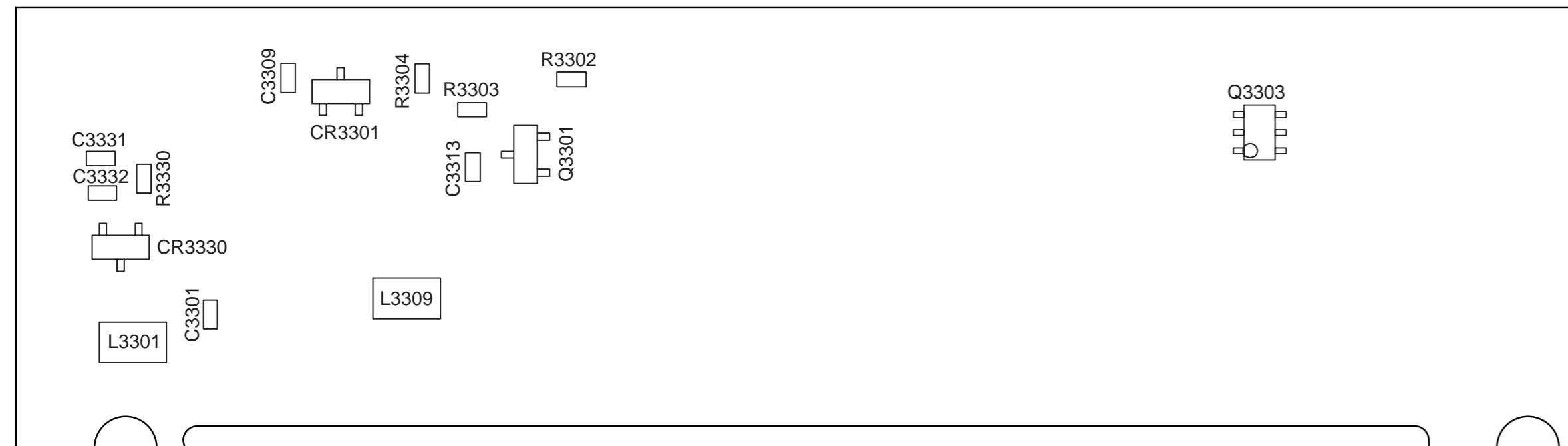

LIGHT COMPONENTS SIDE

MAEPF-26495-O

# RECEIVER FRONT END PARTS LIST

REFERENCE SYMBOL	MOTOROLA PART NUMBER	DESCRIPTION	
C3301	2113741F49	<b>CAPACITORS:</b> 0.01 uF 1000 pF 56 pF 3.3 pF 100 pF 100 pF 100 pF 0.1 uF 1000 pF 100 pF 0.1 uF 0.1 uF 1000 pF 100 pF 330 pF 330 pF 18 p F 7.5 pF 5.6 pF 4.3 pF 8.2 pF 5.1 pF 4.3 pF 6.2 pF 43 pF 56 pF 470 pF 470 pF 43 pF 3.3 pF 1000 pF 1000 pF 0.01 uF 0.01 uF 0.01 uF 0.01 uF 0.01 uF	
C3302	2113741F25		
C3303	2113740F45		
C3304	2113740F15		
C3306	2113740F51		
C3307	2113740F51		
C3308	2113740F51		
C3309	2113743K15		
C3310	2113741F25		
C3312	2113740F51		
C3313	2113741F49		
C3314	2113743K15		
C3315	2113741F25		
C3316	2113741F13		
C3317	2113741F13		
C3320	2113740F33		
C3321	2113740F24		
C3322	2113740F21		
C3323	2113740F18		
C3324	2113740F25		
C3325	2113740F20		
C3326	2113740F18		
C3327	2113740F22		
C3329	2113740F42		
C3330	2113740F45		
C3331	2113741F17		
C3332	2113741F17		
C3334	2113740F42		
C3336	2113740F15		
C3340	2113741F25		
C3341	2113741F25		
C3342	2113741F49		
C3343	2113741F49		
C3346	2113741F49		
C3348	2113741F49		
CR3301	4813833C02		<b>DIODES:</b> Dual, 70V, Common Cathode Dual, Varicap Dual, Schottky Mixer PIN
CR3302	4802081B58		
CR3303	4880154K03		
E3301	2602474Y01		<b>SHIELDS:</b> Preselector
L3301	2462587T30		<b>INDUCTORS:</b> 1000 nH 56 nH 16.03 nH, Airwound 16.03 nH, Airwound 16.03 nH, Airwound 16.03 nH, Airwound 1000 nH 1000 nH 120 nH 120 nH 120 nH 120 nH 120 nH 120 nH 120 nH 1000 nH
L3302	2462587T12		
L3304	2460591L29		
L3305	2460591L29		
L3306	2460591L29		
L3307	2460591L29		
L3308	2462587T30		
L3309	2462587T30		
L3320	2462587T16		
L3321	2462587T16		
L3322	2462587T16		
L3323	2462587T16		
L3325	2462587T12		
L3340	2462587T30		
Q3301	4813824A17	<b>TRANSISTORS:</b> PNP NPN	
Q3302	4882971R01		

REFERENCE SYMBOL	MOTOROLA PART NUMBER	DESCRIPTION
R3301	0662057A97	<b>RESISTORS:</b> 100K 4700 10K 10K 51 10K 270 470 22 270 4.7 10 1000 3300 51 270 22 270
R3302	0662057A65	
R3303	0662057A73	
R3304	0662057A73	
R3305	0662057A18	
R3306	0662057A73	
R3307	0662057A35	
R3308	0662057A41	
R3309	0662057A09	
R3310	0662057A35	
R3311	0662057C19	
R3312	0662057A01	
R3313	0662057A49	
R3330	0662057A61	
R3341	0662057A18	
R3343	0662057A35	
R3344	0662057A09	
R3345	0662057A35	
T3301	2505515V03	<b>TRANSFORMERS:</b> 4:1 BALUN 4:1 BALUN 4:1 BALUN
T3302	2505515V03	
T3303	2505515V07	
	8402573Y06 and 8402573Y09	<b>Printed Circuit Board (For Reference Only):</b> For Kit HUD4012D

- NOTES:
- All resistance values are in ohms unless indicated otherwise.
  - Components shown on component location and schematic diagrams but not included in parts list are not placed.

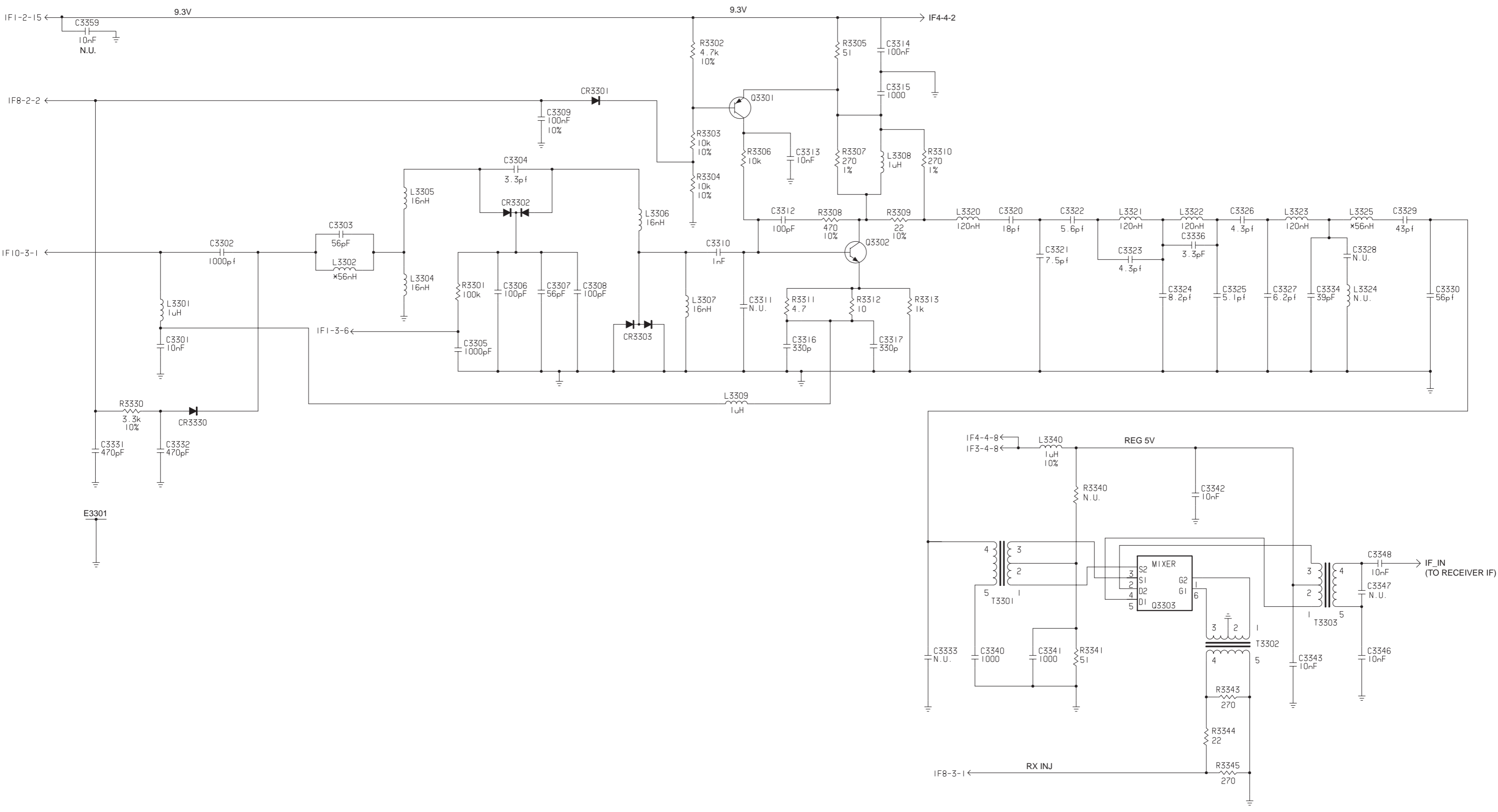

# RECEIVER IF COMPONENT LOCATIONS

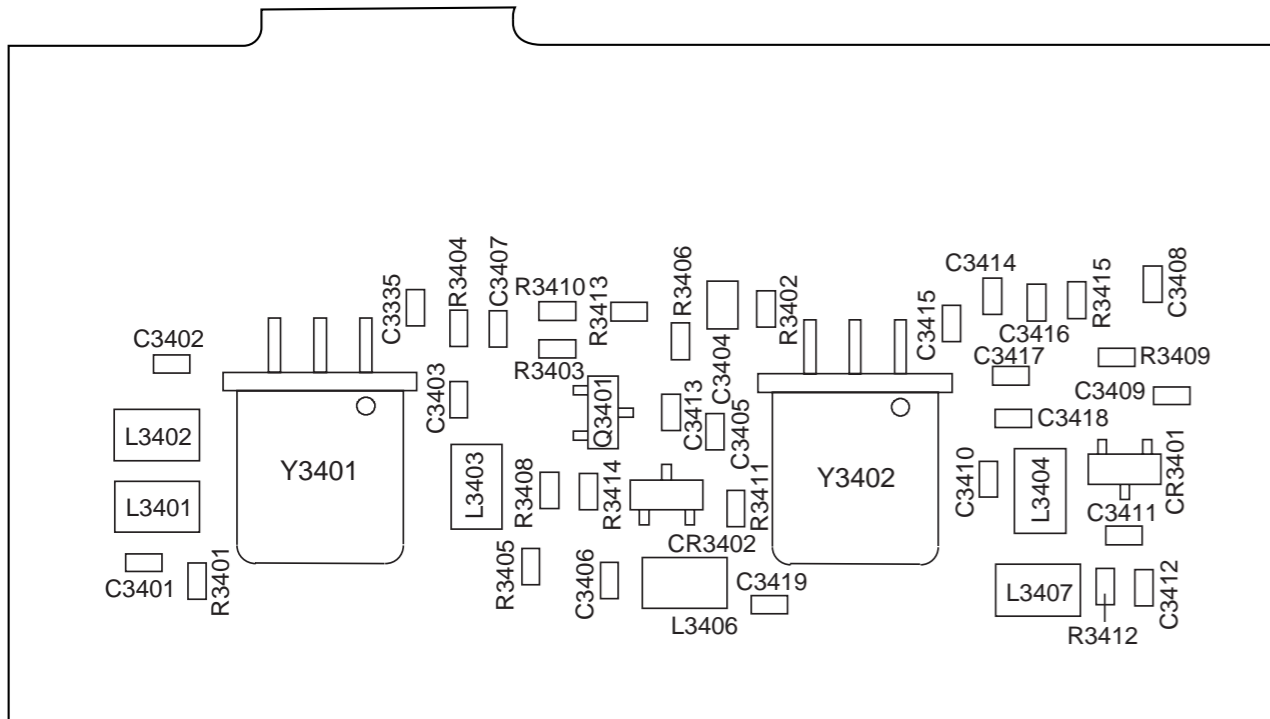

HEAVY COMPONENTS SIDE

MAEPF-26496-O

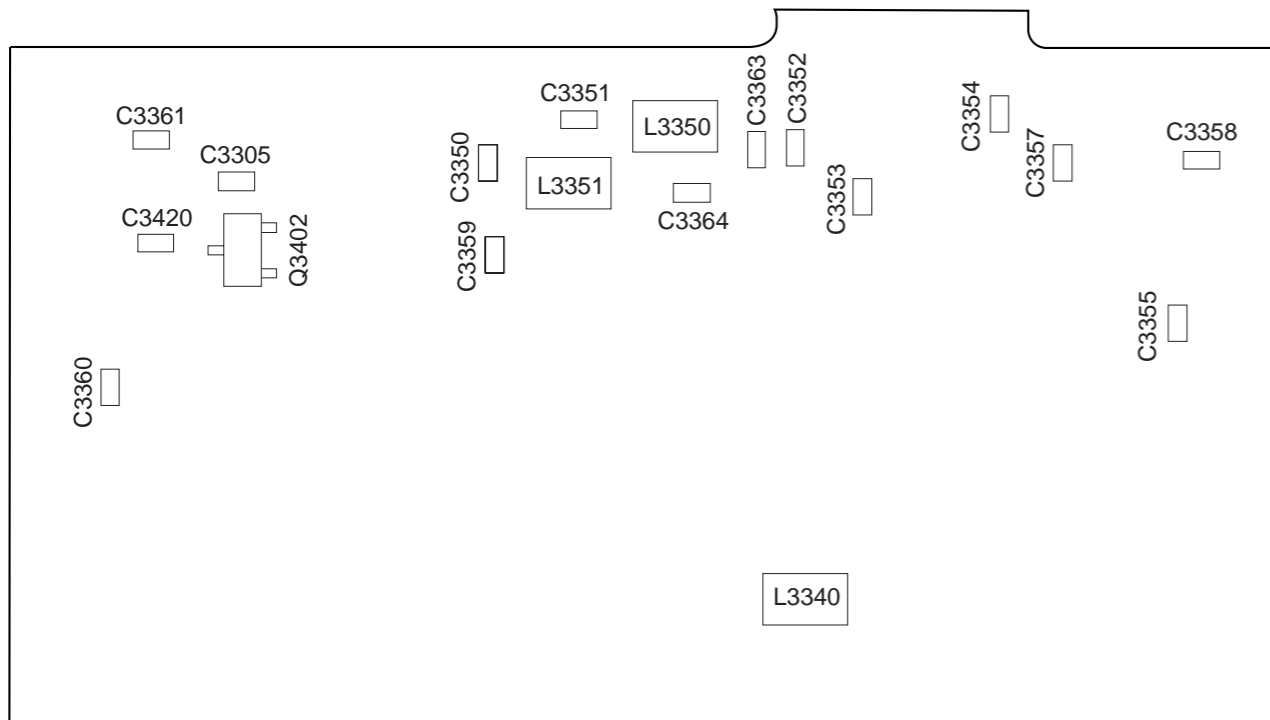

LIGHT COMPONENTS SIDE

MAEPF-26497-O

## RECEIVER IF PARTS LIST

REFERENCE SYMBOL	MOTOROLA PART NUMBER	DESCRIPTION
		<b>CAPACITORS:</b>
C3305	2113741F49	0.01 uF
C3335	2113740F18	4.3 pF
C3350	2113740F51	100 pF
C3351	2113740F51	100 pF
C3352	2113740F51	100 pF
C3353	2113740F51	100 pF
C3355	2113740F51	100 pF
C3357	2113740F51	100 pF
C3358	2113741F58	100 pF
C3359	2113741F49	0.01 uF
C3360	2113740F51	100 pF
C3361	2113740F51	100 pF
C3401	2113740F24	7.5 pF
C3402	2113740F25	8.2 pF
C3403	2113740F31	15 pF
C3404	2113743A19	0.1 uF
C3405	2113740F24	7.5 pF
C3406	2113741F49	0.01 uF
C3407	2113740F51	100 pF
C3408	2113741F49	0.01 uF
C3409	2113741F49	0.01 uF
C3410	2113740F15	3.3 pF
C3411	2113741F13	330 pF
C3412	2113740F25	8.2 pF
C3413	2113741F25	1000 pF
C3414	2113740F09	1.8 pF
C3415	2113740F09	1.8 pF
C3416	2113740F27	10 pF
C3417	2113740F45	56 pF
C3418	2113740F31	15 pF
C3419	2113740F44	51 pF
		<b>DIODES:</b>
CR3401	4880142L01	PIN
CR3402	4880154K03	Dual Schottky Mixer
		<b>INDUCTORS:</b>
L3401	2462587T30	1000 nH
L3402	2462587T30	1000 nH
L3403	2462587T30	1000 nH
L3404	2462587T30	1000 nH
L3406	2462587T30	1000 nH
L3407	2462587T30	1000 nH
		<b>TRANSISTORS:</b>
Q3303	5105625U28	Mixer, Integrated Circuit
Q3401	4882022N70	NPN
		<b>RESISTORS:</b>
R3401	0662057A18	51
R3402	0662057A18	51
R3403	0662057A73	10K
R3404	0662057A73	10K
R3405	0662057A35	270
R3406	0662057A39	390
R3408	0662057A01	10
R3409	0662057A49	1000
R3410	0662057A59	2700
R3411	0662057A41	470
R3412	0662057A53	1500
R3413	0662057A39	390
R3414	0662057A01	10
R3415	0662057A73	10K

REFERENCE SYMBOL	MOTOROLA PART NUMBER	DESCRIPTION
Y3401	4805846W01	<b>FILTERS:</b> Crystal, 44.85 MHz
Y3402	4805846W03	Crystal, 44.85 MHz
	8402573Y06 and 8402573Y09	<b>PRINTED CIRCUIT BOARD (For Reference Only):</b> For Kit HUD4012D

**NOTES:**

1. All resistance values are in ohms unless indicated otherwise.
2. Components shown on component location and schematic diagrams but not included in parts list are not placed.

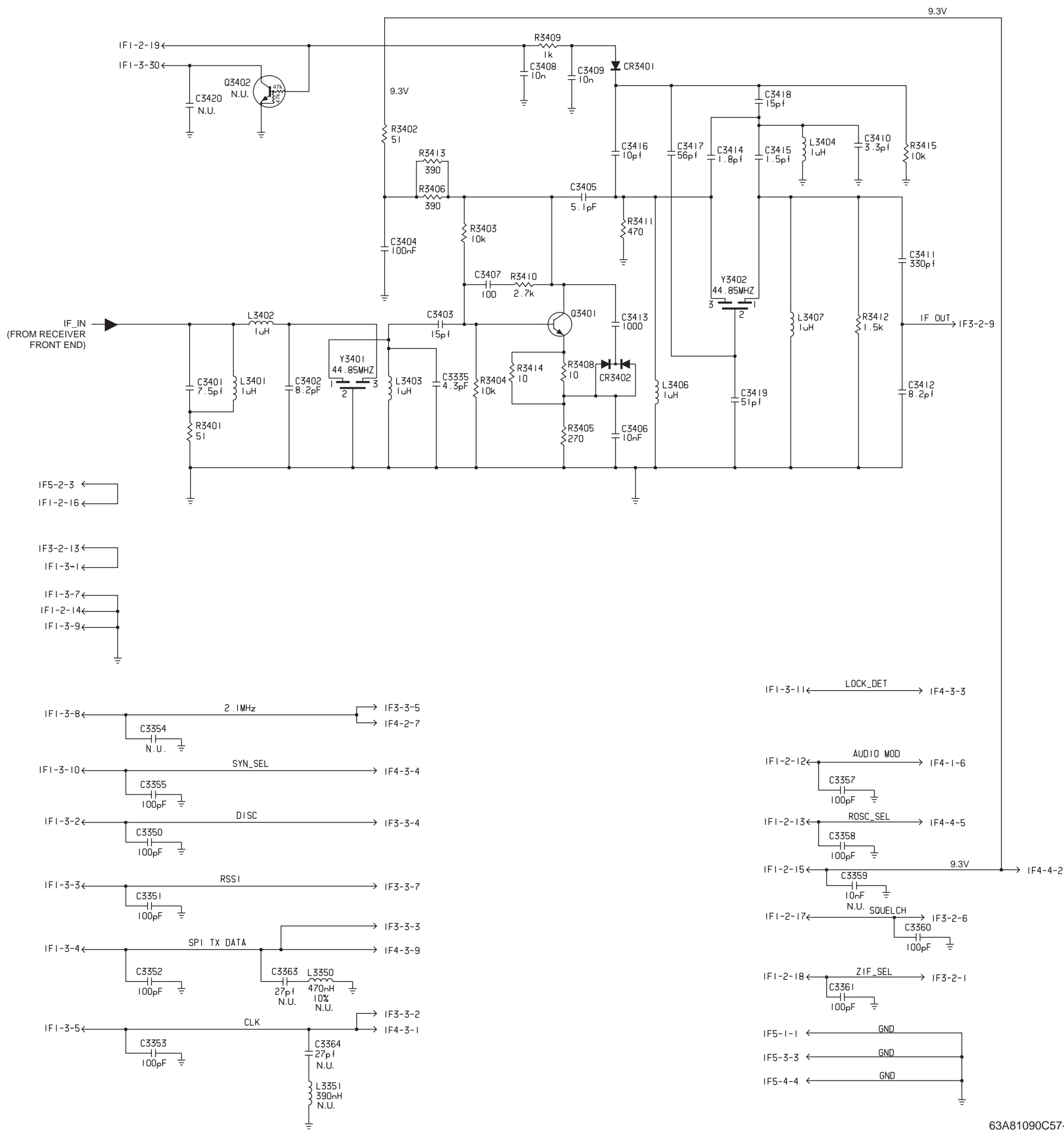

# RECEIVER BACK END COMPONENT LOCATIONS

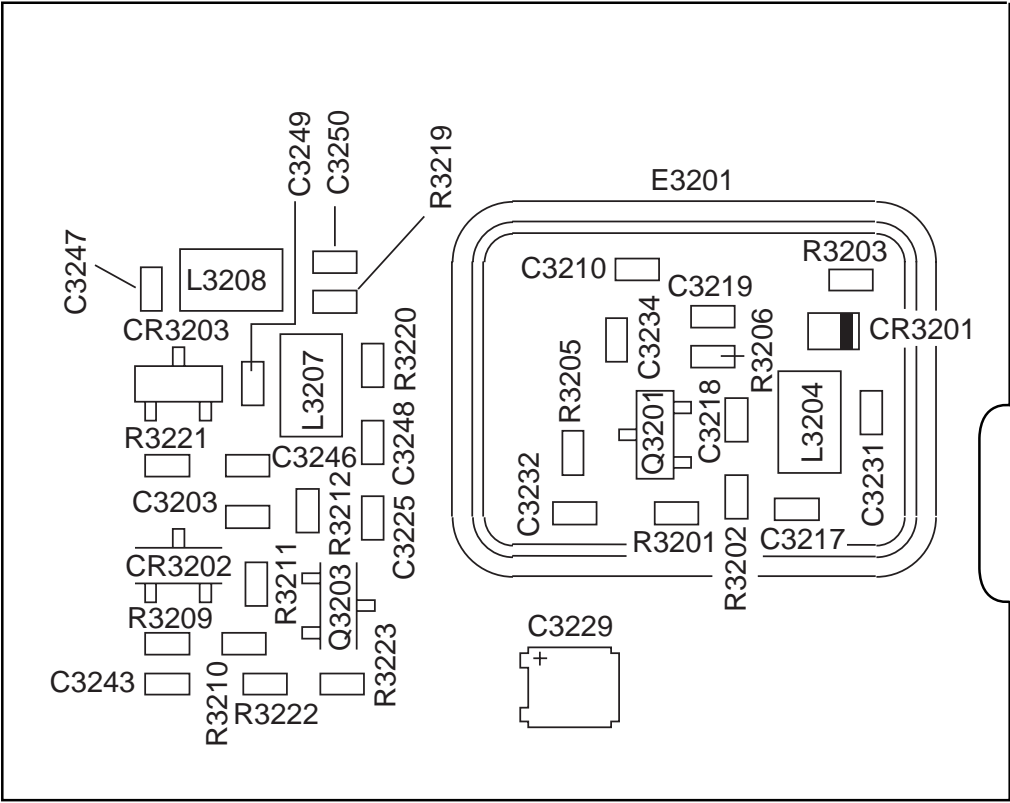

MAEPF-26498-O

HEAVY  
COMPONENTS  
SIDE

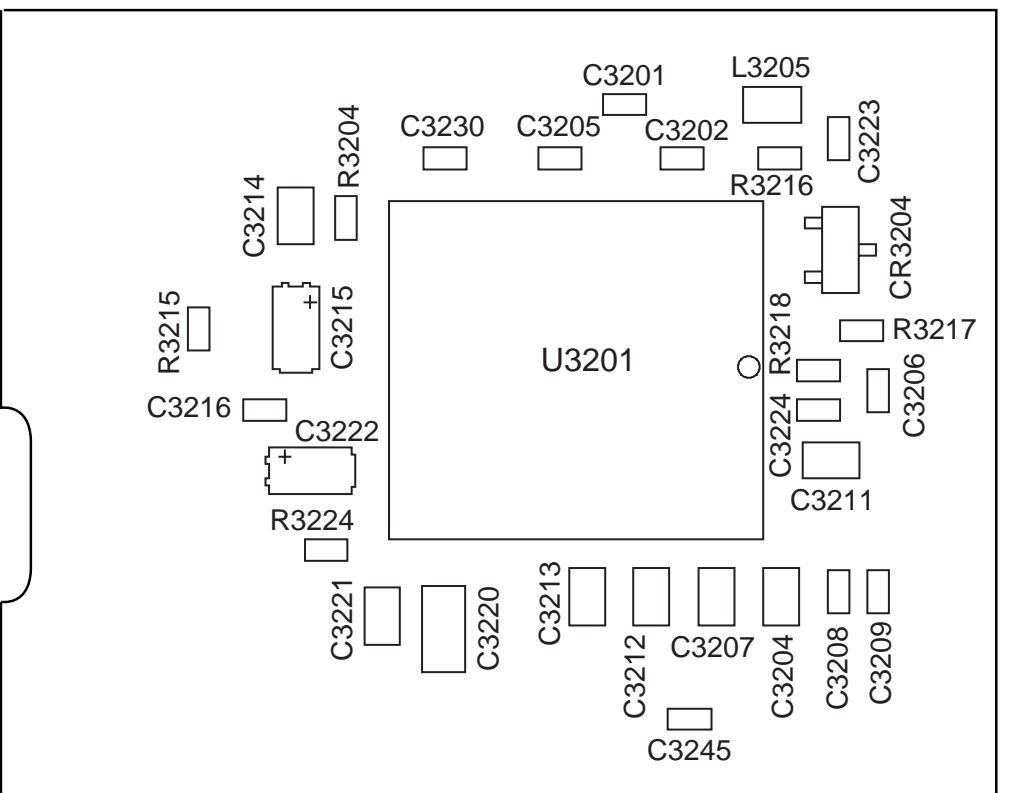

MAEPF-26499-O

LIGHT  
COMPONENTS  
SIDE

## RECEIVER BACK END PARTS LIST

REFERENCE SYMBOL	MOTOROLA PART NUMBER	DESCRIPTION
C3201	2113743K15	<b>CAPACITORS:</b> 0.1 uF 100 pF 0.1 uF 0.22 uF 0.1 uF 0.1 uF 0.22 uF 0.1uF 0.1uF 2113743A23 2113743K15 2113743K15 2113743A23 2113743K15 2113743A23 2113743K15 2113743A23 2113743K15 2113743A19 2113743A23 2113743A23 2113743A23 2113741A51 2311049A02 2113743K15 2113743K15 2113740F37 2113740F41 2113740F42 2109720D14 2113741F17 2109720D14 2113743K15 2113743K15 2113743K15 2311049J23 2113743K15 2113741F25 2113743K15 2113740F19 2113743K15 2113743K15 2113741F49 2113740F15 2113740F22  <b>DIODES:</b> Varactor Dual Dual Schottky Mixer  <b>SHIELD:</b> ZIF  <b>INDUCTORS:</b> 470 nH 560 nH 470 nH 1000 nH  <b>TRANSISTORS:</b> NPN NPN
C3202	2113740F51	
C3203	2113743K15	
C3204	2113743A23	
C3205	2113743K15	
C3206	2113743K15	
C3207	2113743A23	
C3208	2113743K15	
C3209	2113743K15	
C3210	2113740F41	
C3211	2113743A19	
C3212	2113743A23	
C3213	2113743A23	
C3214	2113741A51	
C3215	2311049A02	
C3216	2113743K15	
C3217	2113740F37	
C3218	2113740F41	
C3219	2113740F42	
C3220	2109720D14	
C3221	2113741F17	
C3222	2109720D14	
C3223	2113743K15	
C3224	2113743K15	
C3225	2113743K15	
C3229	2311049J23	
C3230	2113743K15	
C3231	2113741F25	
C3232	2113743K15	
C3234	2113740F19	
C3243	2113743K15	
C3245	2113743K15	
C3246	2113743K15	
C3247	2113741F49	
C3249	2113740F15	
C3250	2113740F22	
CR3201	4862824C01	
CR3203	4805129M96	
CR3204	4880154K03	
E3201	2605261V01	
L3204	2462587T23	
L3205	2462587Q44	
L3207	2462587T23	
L3208	2462587T30	
Q3201	4882022N70	
Q3203	4882022N70	

REFERENCE SYMBOL	MOTOROLA PART NUMBER	DESCRIPTION	
R3201	0662057A89	<b>RESISTORS:</b> 47K 47K 20K 2.7K 2.7K 2.7K 2.7K 1.5K 0 30K 10K 200K 510 1.5K 1.5K 4.7K 22K 1.5K 10K 15K	
R3202	0662057A89		
R3203	0662057A80		
R3204	0662057A59		
R3205	0662057A59		
R3206	0662057A59		
R3209	0662057A53		
R3210	0662057B47		
R3211	0662057A84		
R3212	0662057A73		
R3215	0662057B05		
R3216	0662057A42		
R3217	0662057A53		
R3218	0662057A53		
R3219	0662057A65		
R3220	0662057A81		
R3221	0662057A53		
R3222	0662057A73		
R3223	0662057A77		
U3201	5186296A02		<b>INTEGRATED CIRCUITS:</b> Zero IF, F91 P-3 <b>PRINTED CIRCUIT BOARD (For Reference Only):</b> For Kit HUD4012D
	8402573Y06 and 8402573Y09		

- NOTES:
- All resistance values are in ohms unless indicated otherwise.
  - Components shown on component location and schematic diagrams but not included in parts list are not placed.

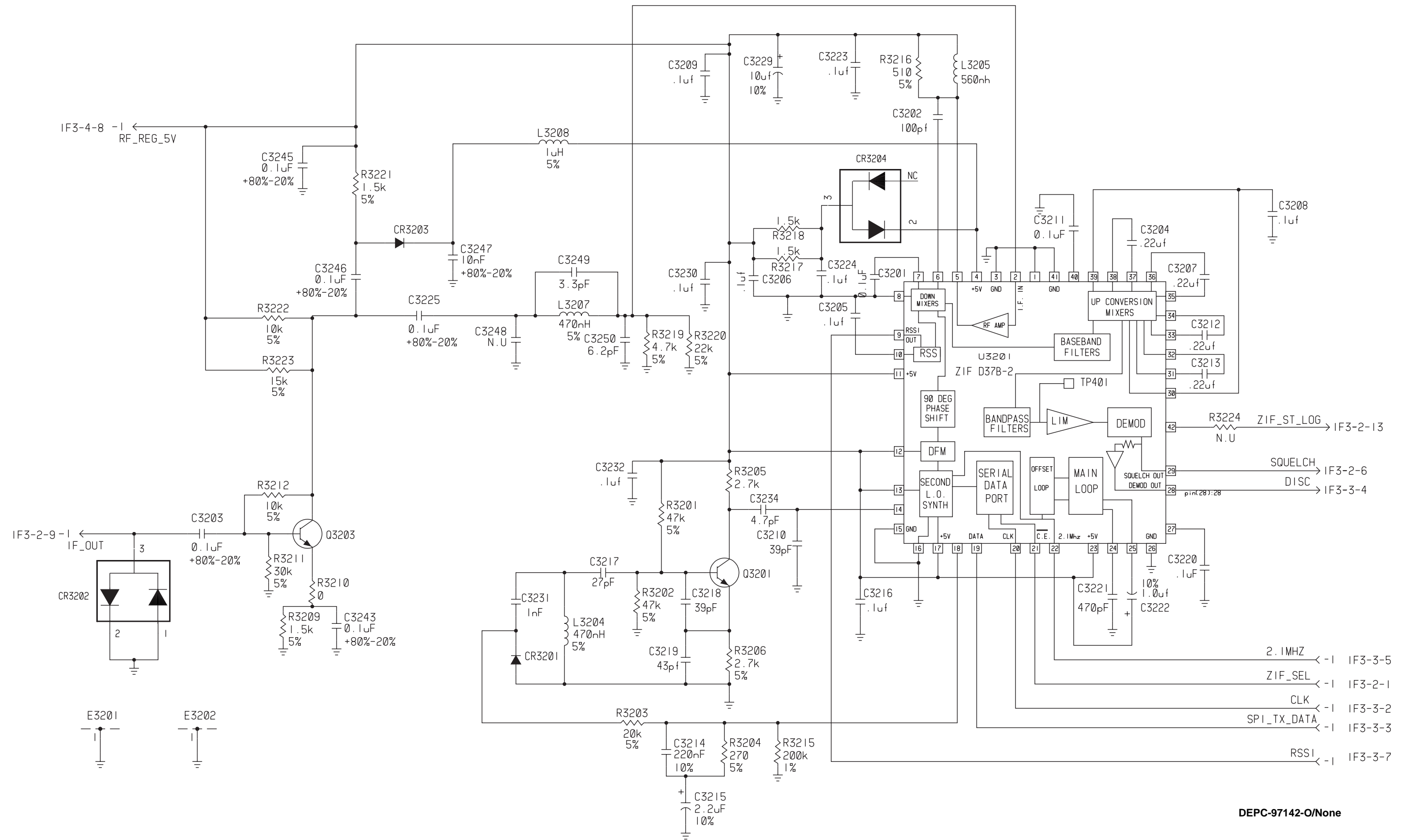

DEPC-97142-O/None

# SYNTHESIZER COMPONENT LOCATIONS

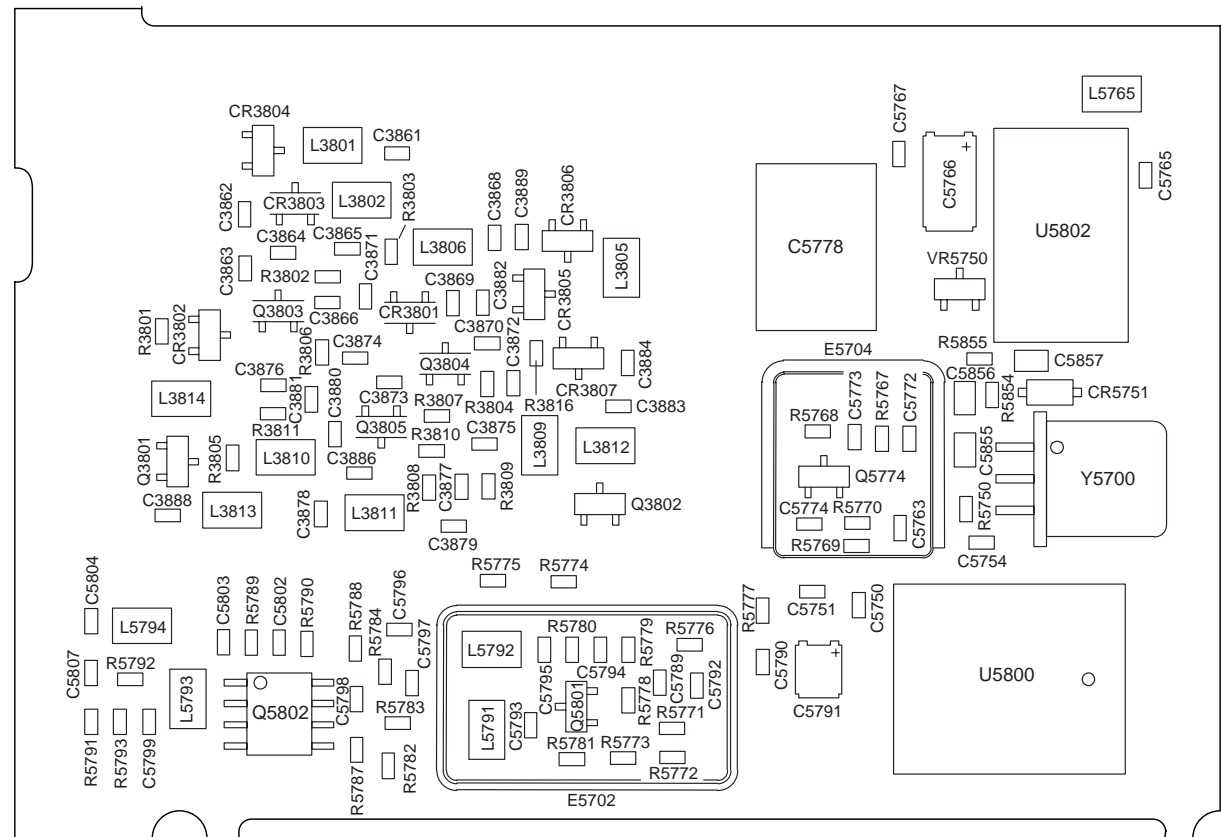

MAEPF-26500-O

HEAVY COMPONENTS SIDE

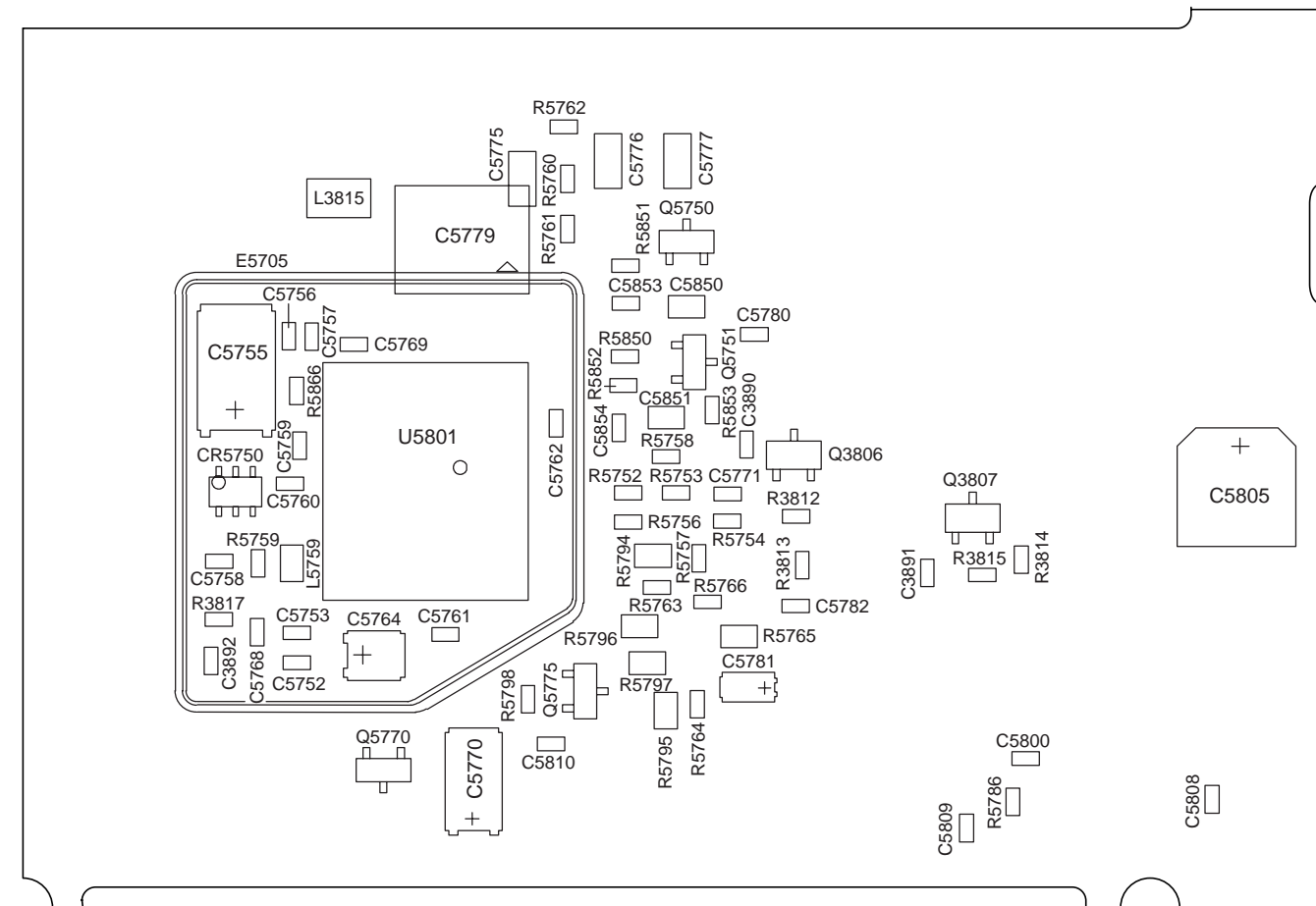

MAEPF-26501-O

LIGHT COMPONENTS SIDE

## SYNTHESIZER PARTS LIST

REFERENCE SYMBOL	MOTOROLA PART NO.	DESCRIPTION
<b>CAPACITORS:</b>		
C3861	2113741F17	470 pF
C3862	2113740F42	43 pF
C3863	2113740F37	27 pF
C3864	2113740F27	10 pF
C3865	2113740F27	10 pF
C3866	2113741F17	470 pF
C3868	2113740F45	56 pF
C3869	2113740F39	33 pF
C3870	2113740F27	10 pF
C3871	2113740F29	12 pF
C3872	2113741F17	470 pF
C3873	2113740F18	4.3 pF
C3874	2113740F18	4.3 pF
C3875	2113741F17	470 pF
C3876	2113741F17	470 pF
C3877	2113741F17	470 pF
C3878	2113740F29	12 pF
C3879	2113740F34	20 pF

REFERENCE SYMBOL	MOTOROLA PART NO.	DESCRIPTION
C3880	2113740F21	5.6 pF
C3881	2113741F17	470 pF
C3882	2113740F07	1.5 pF
C3883	2113740F25	8.2 pF
C3884	2113741F17	470 pF
C3886	2113740F29	12 pF
C3888	2113743K15	0.1 uF
C3889	2113740F35	22 pF
C3890	2113741F17	470 pF
C3891	2113741F17	470 pF
C3892	2113740F45	56 pF
C5750	2113741F49	0.01 uF
C5751	2113743E07	0.022 uF
C5752	2113741F49	0.01 uF
C5753	2113743K07	0.047 uF
C5754	2113743E07	0.022 uF
C5755	2311049A19	10 uF
C5756	2113741F49	0.01 uF
C5757	2113743K15	0.1 uF
C5758	2113743K15	0.1 uF
C5759	2113743K15	0.1 uF

REFERENCE SYMBOL	MOTOROLA PART NO.	DESCRIPTION
C5760	2113743K15	0.1 uF
C5761	2113741F25	1000 uF
C5762	2113743E07	0.022 uF
C5763	2113741F49	0.01 uF
C5764	2311049J23	10 uF
C5765	2113743K15	0.1 uF
C5766	2311049J26	10 uF
C5767	2113743K15	0.1 uF
C5768	2113740F51	100 pF
C5769	2113741F25	1000 pF
C5770	2311049J26	10 uF
C5771	2113741F25	1000 pF
C5772	2113741F25	1000 pF
C5773	2113741F49	0.01 uF
C5774	2113741F49	0.01 uF
C5775	2109720D14	0.1 uF
C5776	2109720D14	0.1 uF
C5777	2109720D14	0.1 uF
C5778	0811051A19	1 uF
C5780	2113741F25	1000 pF
C5781	2311049A07	1 uF
C5782	2113741F25	1000 pF
C5789	2113743K15	0.1 uF
C5790	2113743K15	0.1 uF
C5791	2311049J11	4.7 uF
C5792	2113743K15	0.1 uF
C5793	2113741F25	1000 pF
C5794	2113741F17	470 pF
C5795	2113740F31	15 pF
C5796	2113740F27	10 pF
C5797	2113741F17	470 pF
C5798	2113741F17	470 pF
C5799	2113741F25	1000 pF
C5800	2113743K15	0.1 uF
C5802	2113741F17	470 pF
C5803	2113740F29	12 pF
C5807	2113741F25	1000 pF
C5808	2113740F51	100 pF
C5809	2113741F25	1000 pF
C5850	2113743A19	0.1 uF
C5853	2113740F51	100 pF
<b>DIODES:</b>		
CR3801	4880236E05	Hot Carrier
CR3802	4880236E05	Hot Carrier
CR3803	4805649Q13	Varactor
CR3804	4805649Q13	Varactor
CR3805	4805649Q13	Varactor
CR3806	4805649Q13	Varactor
CR3807	4805649Q13	Varactor
CR5750	4802233J09	Triple
<b>SHIELDS:</b>		
E3801	2602641Y01	VCO
E5702	2602660J02	
E5704	2605259V01	
E5705	2602658J02	
<b>INDUCTORS:</b>		
L3801	2462587T30	1000 nH
L3802	2462587T30	1000 nH
L3804	0105950T44	Helical Coil, Square
L3805	2462587T30	1000 nH
L3806	2462587T20	270 nH
L3808	0105950T45	Helical Coil, Square
L3809	2462587T30	1000 nH

REFERENCE SYMBOL	MOTOROLA PART NO.	DESCRIPTION
L3810	2462587T13	68 nH
L3811	2462587T12	56 nH
L3812	2462587T13	68 nH
L3813	2462587T30	1000 nH
L3814	2462587T30	1000 nH
L3815	2462587T20	270 nH
L5765	L2462587T17	150 nH
L5791	2462587T16	120 nH
L5792	2462587T12	56 nH
L5793	2462587T16	120 nH
L5794	2462587T13	68 nH
<b>TRANSISTORS:</b>		
Q3801	4813824A10	NPN
Q3802	4813824A10	NPN
Q3803	4813823A05	N-Channel RFJFET
Q3804	4813823A05	N-Channel RF JFET
Q3805	4882022N70	NPN
Q3806	4880048M01	NPN
Q3807	4880048M01	NPN
Q5750	4813824A17	PNP
Q5770	4813824A17	PNP
Q5774	4882022N70	NPN
Q5801	4882022N70	NPN
Q5802	4813827A26	NPN
<b>RESISTORS:</b>		
R3801	0662057A83	27K
R3802	0662057A33	220
R3803	0662057A83	27K
R3804	0662057A25	100
R3805	0662057A39	390
R3806	0662057A15	39
R3807	0662057A15	39
R3808	0662057A59	2.7K
R3809	0662057A59	2.7K
R3810	0662057A77	15K
R3811	0662057A43	560
R3812	0662057A59	2.7K
R3813	0662057A59	2.7K
R3814	0662057A59	2.7K
R3815	0662057A59	2.7K
R3816	0662057A18	51
R3817	0662057A43	560
R5750	0662057A65	4.7K
R5752	0662057B02	150K
R5753	0662057B02	150K
R5754	0662057A53	1.5K
R5758	0662057A57	2.2K
R5759	0662057A35	270
R5760	0662057A49	1K
R5761	0662057A25	100
R5762	0662057A41	470
R5763	0662057A59	2.7K
R5764	0662057A53	1.5K
R5766	0662057B02	150K
R5767	0662057A35	270
R5768	0662057A59	2.7K
R5769	0662057A49	1K
R5770	0662057B47	0
R5771	0662057A43	560
R5772	0662057A18	51
R5773	0662057A25	100
R5774	0662057A09	22
R5775	0662057A35	270
R5776	0662057A35	270

REFERENCE SYMBOL	MOTOROLA PART NO.	DESCRIPTION
R5777	0662057A09	22
R5778	0662057A59	2.7K
R5779	0662057A49	1K
R5780	0662057A09	22
R5781	0662057A13	33
R5782	0662057A29	150
R5783	0662057A15	39
R5784	0662057A29	150
R5786	0662057A13	33
R5787	0662057A56	2K
R5788	0662057A49	1K
R5789	0662057A29	150
R5790	0662057A29	150
R5791	0662057A29	150
R5792	0662057A15	39
R5793	0662057A29	150
R5850	0662057A89	47K
R5851	0662057A89	47K
R5866	0662057B47	0
<b>INTEGRATED CIRCUITS:</b>		
U5800	5105279V38	Oscillator, 16.8 MHz
U5801	5105457W73	FRACTN
U5802	5113816A07	Regulator, 5 VDC, 500 mA
<b>ZENER DIODE:</b>		
VR5750	481380A23	10 VDC, 225 mW
<b>PRINTED CIRCUIT BOARD (For reference only):</b>		
	8402573Y06 and 8402573Y09	For kit HUD4012D

### NOTES:

- All resistance values are in ohms unless indicated otherwise.
- Components shown on component location and schematic diagrams but not included in parts list are not placed



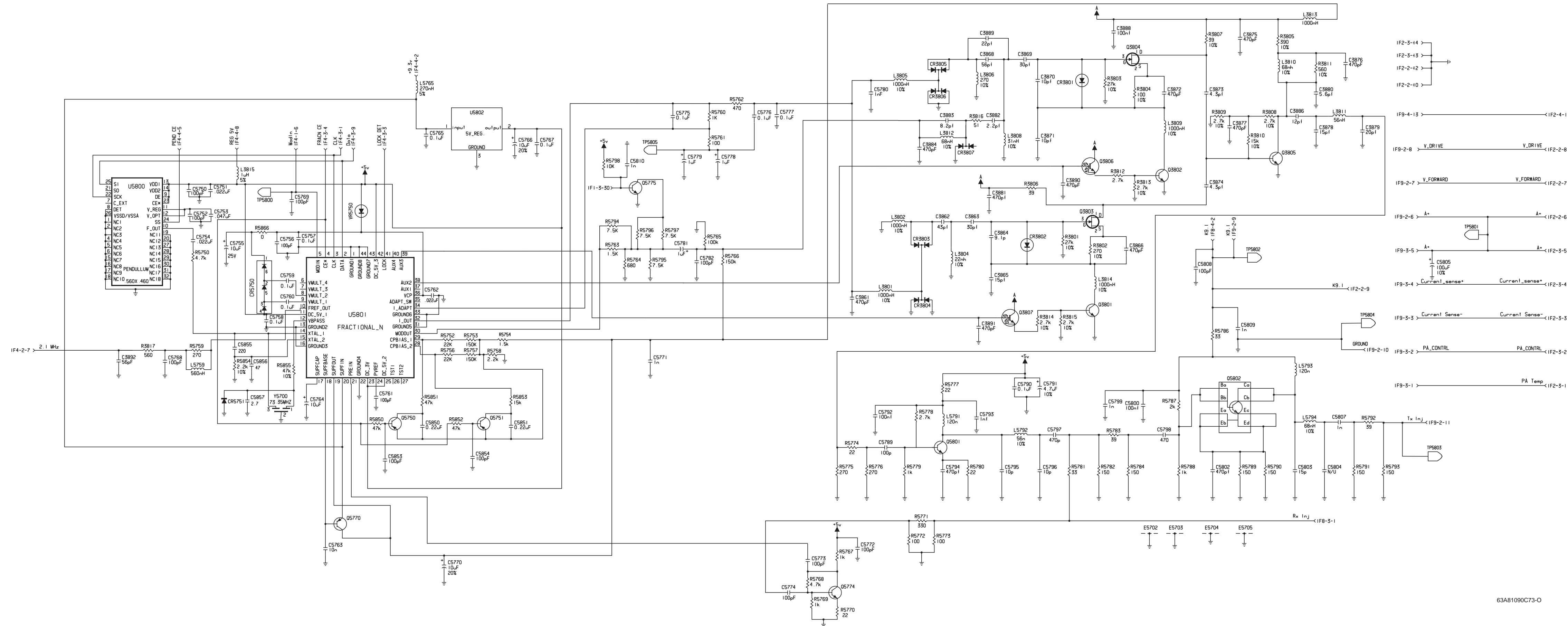

63A81090C73-O



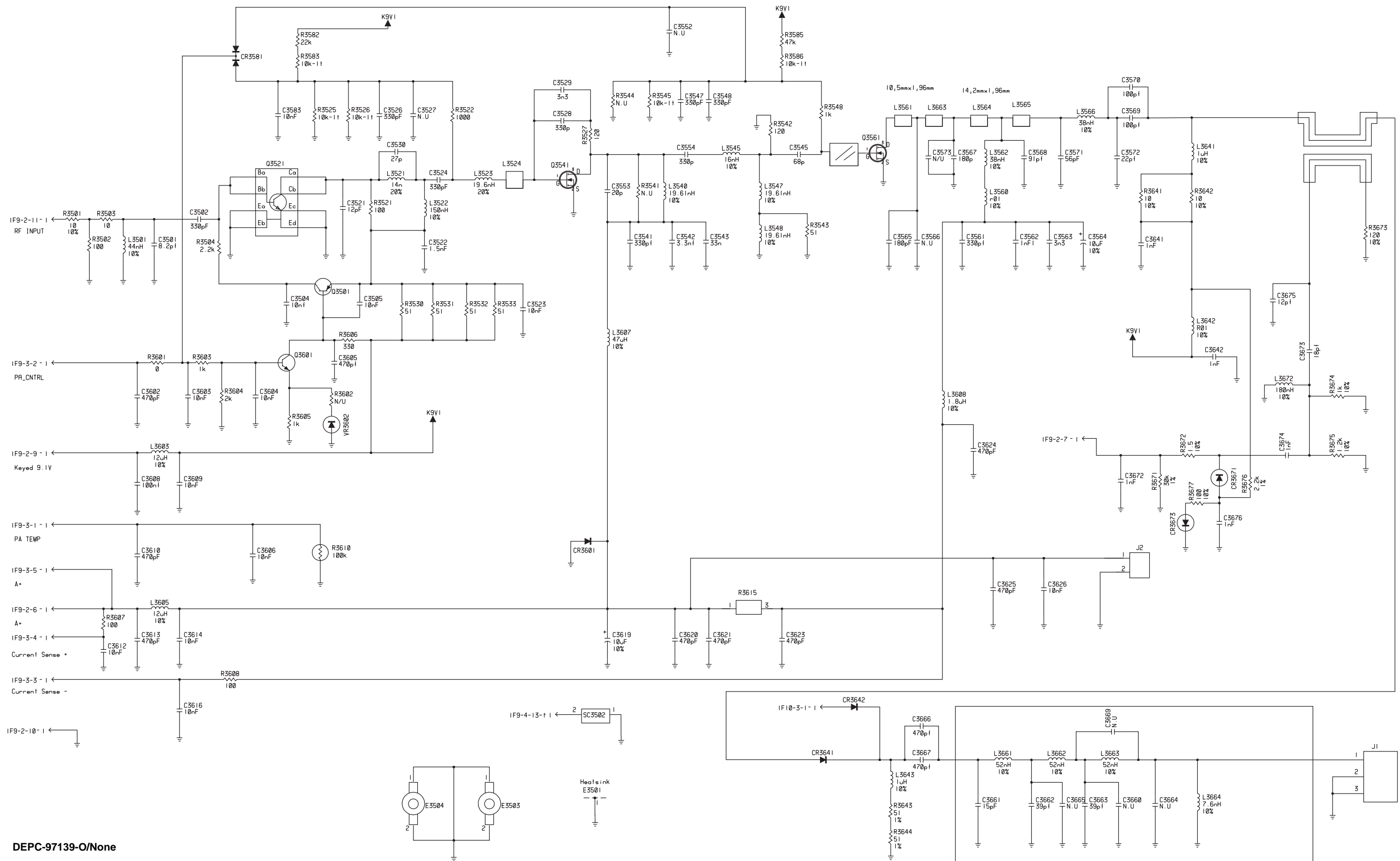

DEPC-97139-O/None

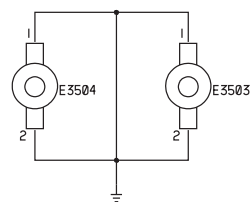

---

### Q3541 Bias Measurement and Adjustment Procedure:

1. Disconnect A+ supply from radio.
2. Remove resistor R3503 and ferrite bead L3607 from PCB.
3. On PCB, tack solder wires onto pads for L3607 temporarily and connect the wires to a digital milliammeter.
4. Reconnect A+ supply to radio. Set A+ supply to 13.6 volts, and current limit to 4.0 Amperes.
5. Key up transmitter and observe current indicated on milliammeter. If current is between 120 and 180 milliamperes, skip to step 14. Otherwise, proceed to step 6.
6. Dekey transmitter and disconnect A+ supply from radio.
7. Remove trim resistors R3525 and R3526 from PCB.
8. Place a 10K Ohm resistor in place of R3525.
9. Reconnect A+ supply to radio. Set A+ supply to 13.6 volts, and current limit to 4.0 Amperes.
10. Key up transmitter and observe current indicated on milliammeter. If current is between 120 and 180 milliamperes, skip to step 14. Otherwise, proceed to step 11.
11. Dekey transmitter and disconnect A+ supply from radio.

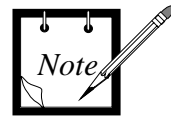

In step 12 and/or 13, if the required current level of 120- to 180-milliamperes cannot be obtained using a standard value resistor for R3525, place a resistor on pads for R3526 to form a parallel resistance network with R3525. The parallel resistance (R) of R3525 and R3526 is:  $R = R3525 * R3526 / (R3525 + R3526)$ .

12. If current observed in step 10 is less than 120 milliamperes, replace R3525 with next higher standard value (i.e., 12K) and repeat steps 9 and 10. Otherwise, proceed to step 13.
13. If current observed in step 10 is more than 180 milliamperes, replace R3525 with next lower standard value (i.e., 9.1K) and repeat steps 9 and 10.
14. Dekey transmitter, disconnect A+ supply from radio, and disconnect milliammeter wires from PCB.
15. Reinstall R3503 and L3607 on PCB.

---

### Q3561 Bias Measurement and Adjustment Procedure:

1. Disconnect A+ supply from radio.
2. Remove resistor R3503 and ferrite bead L3560 from PCB.
3. On PCB, tack solder wires onto pads for L3560 temporarily and connect the wires to a digital milliammeter.
4. Reconnect A+ supply to radio. Set A+ supply to 13.6 volts, and current limit to 4.0 Amperes.
5. Key up transmitter and observe current indicated on milliammeter. If current is between 1400 and 2200 milliamperes, skip to step 14. Otherwise, proceed to step 6.
6. Dekey transmitter and disconnect A+ supply from radio.
7. Remove trim resistor R3545 from PCB.
8. Place a 10K Ohm resistor in place of R3545.
9. Reconnect A+ supply to radio. Set A+ supply to 13.6 volts, and current limit to 4.0 Amperes.
10. Key up transmitter and observe current indicated on milliammeter. If current is between 1400 and 2200 milliamperes, skip to step 14. Otherwise, proceed to step 11.
11. Dekey transmitter and disconnect A+ supply from radio.



In step 12 and/or 13, if the required current level of 1400- to 2200-milliamperes cannot be obtained using a standard value resistor for R3545, place a resistor on pads for R3544 to form a parallel resistance network with R3545. The parallel resistance (R) of R3544 and R3545 is:  $R = R3544 * R3545 / (R3544 + R3545)$ .

12. If current observed in step 10 is less than 1400 milliamperes, replace R3545 with next higher standard value (i.e., 12K) and repeat steps 9 and 10. Otherwise, proceed to step 13.
13. If current observed in step 10 is more than 2200 milliamperes, replace R3545 with next lower standard value (i.e., 9.1K) and repeat steps 9 and 10.
14. Dekey transmitter, disconnect A+ supply from radio, and disconnect milliammeter wires from PCB.
15. Reinstall R3503 and L3560 on PCB.

Table 1: Schematic Diagram Interconnection List

From/To				From/To			
Node	Signal Name	Schematic Diagram Title	Publication	Node	Signal Name	Schematic Diagram Title	Publication
IF1-2-12	AUDIO_MOD	Main Controller Block Diagram	68P81083C20	IF1-2-12	AUDIO_MOD	Receiver IF	68P81080C48
IF1-2-13	ROSC_SEL	Main Controller Block Diagram	68P81083C20	IF1-2-13	ROSC_SEL	Receiver IF	68P81080C48
IF1-2-14	GND	Main Controller Block Diagram	68P81083C20	IF1-2-14	GND	Receiver IF	68P81080C48
IF1-2-15	9V3	Main Controller Block Diagram	68P81083C20	IF1-2-15	9.3V	Receiver Front End and Receiver IF	68P81080C48
IF1-2-16	PA_CNTL_LIM	Main Controller Block Diagram	68P81083C20	IF1-2-16	Not Indicated	Receiver IF	68P81080C48
IF1-2-17	SQUELCH	Main Controller Block Diagram	68P81083C20	IF1-2-17	SQUELCH	Receiver IF	68P81080C48
IF1-2-18	ZIF_SEL	Main Controller Block Diagram	68P81083C20	IF1-2-18	ZIF_SEL	Receiver IF	68P81080C48
IF1-2-19	DUPLEX_SYN_SEL	Main Controller Block Diagram	68P81083C20	IF1-2-19	Not Indicated	Receiver IF	68P81080C48
IF1-3-1	DUPLEX_LOCK_DET	Main Controller Block Diagram	68P81083C20	IF1-3-1	Not Indicated	Receiver IF	68P81080C48
IF1-3-2	DISC	Main Controller Block Diagram	68P81083C20	IF1-3-2	DISC	Receiver IF	68P81080C48
IF1-3-3	RSSI	Main Controller Block Diagram	68P81083C20	IF1-3-3	RSSI	Receiver IF	68P81080C48

Table 1: Schematic Diagram Interconnection List

From/To				From/To			
Node	Signal Name	Schematic Diagram Title	Publication	Node	Signal Name	Schematic Diagram Title	Publication
IF1-3-4	SDATA	Main Controller Block Diagram	68P81083C20	IF1-3-4	SPI TX DATA	Receiver IF	68P81080C48
IF1-3-5	SCLK	Main Controller Block Diagram	68P81083C20	IF1-3-5	CLK	Receiver IF	68P81080C48
IF1-3-6	RX_CNTL_I_SRC	Main Controller Block Diagram	68P81083C20	IF1-3-6	Not Indicated	Receiver Front End	68P81080C48
IF1-3-7	GND	Main Controller Block Diagram	68P81083C20	IF1-3-7	GND	Receiver IF	68P81080C48
IF1-3-8	2.1MHz	Main Controller Block Diagram	68P81083C20	IF1-3-8	2.1MHz	Receiver IF	68P81080C48
IF1-3-9	GND	Main Controller Block Diagram	68P81083C20	IF1-3-9	GND	Receiver IF	68P81080C48
IF1-3-10	SYN_SEL	Main Controller Block Diagram	68P81083C20	IF1-3-10	SYN_SEL	Receiver IF	68P81080C48
IF1-3-11	LOCK_DET	Main Controller Block Diagram	68P81083C20	IF1-3-11	LOCK_DET	Receiver IF	68P81080C48
IF1-3-30	Not Indicated	Synthesizer	68P81080C48	IF1-3-30	Not Indicated	Receiver IF	68P81080C48
IF2-2-6	A+	Synthesizer	68P81080C48	IF2-2-6	A+_CONT	Main Controller Block Diagram	68P81083C20
IF2-2-7	V_FORWARD	Synthesizer	68P81080C48	IF2-2-7	V_FORWARD	Main Controller Block Diagram	68P81083C20
IF2-2-8	V_DRIVE	Synthesizer	68P81080C48	IF2-2-8	V_CNTL	Main Controller Block Diagram	68P81083C20
IF2-2-9	K9.1	Synthesizer	68P81080C48	IF2-2-9	K9V1	Main Controller Block Diagram	68P81083C20
IF2-2-10	GND	Synthesizer	68P81080C48	IF2-2-10	GND		

Table 1: Schematic Diagram Interconnection List

From/To				From/To			
Node	Signal Name	Schematic Diagram Title	Publication	Node	Signal Name	Schematic Diagram Title	Publication
IF2-2-12	GND	Synthesizer	68P81080C48				
IF2-3-1	PA Temp	Synthesizer	68P81080C48	IF2-3-1	PA_TEMP	Main Controller Block Diagram	68P81083C20
IF2-3-2	PA_CONTRL	Synthesizer	68P81080C48	IF2-3-2	PA_CNTL	Main Controller Block Diagram	68P81083C20
IF2-3-3	Current_Sense-	Synthesizer	68P81080C48	IF2-3-3	CURRENT_SENSE_-	Main Controller Block Diagram	68P81083C20
IF2-3-4	Current_Sense+	Synthesizer	68P81080C48	IF2-3-4	CURRENT_SENSE_+	Main Controller Block Diagram	68P81083C20
IF2-3-5	A+	Synthesizer	68P81080C48	IF2-3-5	A+_CONT	Main Controller Block Diagram	68P81083C20
IF2-3-13	GND	Synthesizer	68P81080C48				
IF2-3-14	GND	Synthesizer	68P81080C48				
IF2-4-11	GROUND	Synthesizer	68P81080C48	IF2-4-11	GROUND	Main Controller Block Diagram	68P81083C20
IF3-2-1	ZIF_SEL	Receiver IF	68P81080C48	IF3-2-1	ZIF_SEL	Receiver Back End	68P81080C48
IF3-2-6	SQUELCH	Receiver IF	68P81080C48	IF3-2-6	SQUELCH	Receiver Back End	68P81080C48
IF3-2-9	IF OUT	Receiver IF	68P81080C48	IF3-2-9	IF_OUT	Receiver Back End	68P81080C48
IF3-2-13	Not Indicated	Receiver Back End	68P81080C48	IF3-2-13	ZIF_ST_LOG	Receiver Back End	68P81080C48
IF3-3-2	CLK	Receiver IF	68P81080C48	IF3-3-2	CLK	Receiver Back End	68P81080C48
IF3-3-3	SPI TX DATA	Receiver IF	68P81080C48	IF3-3-3	SPI_TX_DATA	Receiver Back End	68P81080C48
IF3-3-4	DISC	Receiver IF	68P81080C48	IF3-3-4	DISC	Receiver Back End	68P81080C48
IF3-3-5	2.1MHz	Receiver IF	68P81080C48	IF3-3-5	2.1Mhz	Receiver Back End	68P81080C48
IF3-3-7	RSSI	Receiver IF	68P81080C48	IF3-3-7	RSSI	Receiver Back End	68P81080C48

Table 1: Schematic Diagram Interconnection List

From/To				From/To			
Node	Signal Name	Schematic Diagram Title	Publication	Node	Signal Name	Schematic Diagram Title	Publication
IF3-4-8	Not Indicated	Receiver Front End	68P81080C48	IF3-4-8	RF_REG_5V	Receiver Back End	68P81080C48
IF4-1-6	Mod In	Synthesizer	68P81080C48	IF4-1-6	AUDIO MOD	Receiver IF	68P81080C48
IF4-2-7	2.1 MHz	Synthesizer	68P81080C48	IF4-2-7	2.1MHz	Receiver IF	68P81080C48
IF4-3-1	CLK	Synthesizer	68P81080C48	IF4-3-1	CLK	Receiver IF	68P81080C48
IF4-3-3	LOCK DET	Synthesizer	68P81080C48	IF4-3-3	LOCK_DET	Receiver IF	68P81080C48
IF4-3-4	FRACN CE	Synthesizer	68P81080C48	IF4-3-4	SYN_SEL	Receiver IF	68P81080C48
IF4-3-9	Data	Synthesizer	68P81080C48	IF4-3-9	SPI TX DATA	Receiver IF	68P81080C48
IF4-4-2	+9.3V	Synthesizer	68P81080C48	IF4-4-2	9.3V	Receiver IF	68P81080C48
IF4-4-5	PEND CE	Synthesizer	68P81080C48	IF4-4-5	ROSC_SEL	Receiver IF	68P81080C48
IF4-4-8	REG 5V	Synthesizer	68P81080C48	IF4-4-8	Regulated 5V	Receiver Front End	68P81080C48
IF5-1-1	GND	Receiver IF	68P81080C48				
IF5-2-3	Jumper	Receiver IF	68P81080C48	1F1-2-16			
IF5-3-3	GND	Receiver IF	68P81080C48				
IF5-4-4	GND	Receiver IF	68P81080C48				
IF7-1-11	SPK+	Main Controller Block Diagram	68P81083C20	IF7-1-11	SPK+	Controller Power Control	68P81083C20
IF7-1-12	SPK-	Main Controller Block Diagram	68P81083C20	IF7-2-12			
IF7-1-15	PA_CNTL	Main Controller Block Diagram	68P81083C20	IF2-3-2			
IF7-1-17	GND	Main Controller Block Diagram	68P81083C20	IF7-1-17	GND	Controller Power Control	68P81083C20
IF7-1-23	PWR_RST	Main Controller Block Diagram	68P81083C20	IF7-1-23	PWR_RST	Controller Power Control	68P81083C20



Table 1: Schematic Diagram Interconnection List

From/To				From/To			
Node	Signal Name	Schematic Diagram Title	Publication	Node	Signal Name	Schematic Diagram Title	Publication
IF7-1-31	TEMP_GND	Main Controller Block Diagram	68P81083C20				
IF7-2-3	V_CNTL			IF7-2-3	V_CNTL	Controller Power Control	68P81083C20
IF7-2-4	V_FORWARD	Main Controller Block Diagram	68P81083C20	IF7-2-4	V_FORWARD	Controller Power Control	68P81083C20
IF7-2-7	UNSW_5V	Main Controller Block Diagram	68P81083C20	IF7-2-7	UNSW_5V	Controller Power Control	68P81083C20
IF7-2-8	CL_UNSW_5V	Main Controller Block Diagram	68P81083C20	IF7-2-8	CL_UNSW_5V	Controller Power Control	68P81083C20
IF7-2-10	RX_AUDIO, IF7-4-10	Main Controller Block Diagram	68P81083C20				
IF7-2-12	SPK-, IF7-1-12	Main Controller Block Diagram	68P81083C20				
IF7-2-13	CURRENT_SENSE_+	Main Controller Block Diagram	68P81083C20	IF7-2-13	CURRENT_SENSE_+	Controller Power Control	68P81083C20
IF7-2-20	CLEAR			IF7-2-20	CLEAR	Controller Power Control	68P81083C20
IF7-2-21	B+_IGNITION	Main Controller Block Diagram	68P81083C20	IF7-2-21	B+_IGNITION	Controller Power Control	68P81083C20
IF7-2-24	A+	Main Controller Block Diagram	68P81083C20				
IF7-2-25	A+_CONT	Main Controller Block Diagram	68P81083C20	IF7-2-25	A+_CONT	Controller Power Control	68P81083C20
IF7-2-26	9V3	Main Controller Block Diagram	68P81083C20	IF7-2-26	9V3	Controller Power Control	68P81083C20
IF7-2-27	SW_B+	Main Controller Block Diagram	68P81083C20	IF7-2-27	SW_B+	Controller Power Control	68P81083C20

Table 1: Schematic Diagram Interconnection List

From/To				From/To			
Node	Signal Name	Schematic Diagram Title	Publication	Node	Signal Name	Schematic Diagram Title	Publication
IF7-2-28	Vdd	Main Controller Block Diagram	68P81083C20	IF7-2-28	Vdd	Controller Power Control	68P81083C20
IF7-2-29	SW_B+	Controller Power Control	68P81083C20	IF7-2-27			
IF7-2-30	9V4			IF7-2-30	9V3	Controller Power Control	68P81083C20
IF7-3-5	K9V1	Main Controller Block Diagram	68P81083C20	IF7-3-5	K9V1	Controller Power Control	68P81083C20
IF7-3-6	PA_TEMP	Main Controller Block Diagram	68P81083C20	IF7-3-6	PA_TEMP	Controller Power Control	68P81083C20
IF7-3-14	CURRENT_SENSE -	Controller Power Control	68P81083C20	IF2-3-3			
IF7-3-15	PA_CNTL	Controller Power Control	68P81083C20	IF2-3-2			
IF7-3-18	Vaud	Main Controller Block Diagram	68P81083C20	IF7-3-18	Vaud	Controller Power Control	68P81083C20
IF7-3-22	+5V	Controller Power Control	68P81083C20	IF7-4-22			
IF7-4-1	VFWD_BUF	Main Controller Block Diagram	68P81083C20	IF7-4-1	VFWD_BUF	Controller Power Control	68P81083C20
IF7-4-2	VSUM	Main Controller Block Diagram	68P81083C20	IF7-4-2	VSUM	Controller Power Control	68P81083C20
IF7-4-9	AUPA_EN	Main Controller Block Diagram	68P81083C20	IF7-4-9	AUPA_EN	Controller Power Control	68P81083C20
1F7-4-10	RX_AUDIO			1F7-2-10			
1F7-4-14	CURRENT_SENSE	Main Controller Block Diagram	68P81083C20	1F2-3-3			
1F7-4-16	A+						

Table 1: Schematic Diagram Interconnection List

From/To				From/To			
Node	Signal Name	Schematic Diagram Title	Publication	Node	Signal Name	Schematic Diagram Title	Publication
1F7-4-19	B+_ON_OFF	Main Controller Block Diagram	68P81083C20				
IF7-4-22	+5V	Main Controller Block Diagram	68P81083C20	IF7-3-22, IF7-4-24	A+	Controller Power Control	68P81083C20
IF8-2-2	K9V1	Receiver Front End	69P81080C48	1F8-4-2		Synthesizer	68P81080C48
IF8-3-1	Rx Inj	Synthesizer	68P81080C48	IF8-3-1	Not Indicated	Receiver Front End	68P81080C48
IF8-4-2	K9.1	Synthesizer	68P81080C48	1F9-2-9		Synthesizer	68P81080C48
IF9-2-6	A+	Power Amplifier	68P81080C48	IF9-2-6	A+	Synthesizer	68P81080C48
IF9-2-7	Not indicated	Power Amplifier	68P81080C48	IF9-2-7	V_FORWARD	Synthesizer	68P81080C48
IF9-2-8	V_DRIVE	Synthesizer	68P81080C48	IF2-2-8			
IF9-2-9	Keyed 9.1V	Power Amplifier	68P81080C48	IF9-2-9	K9.1	Synthesizer	68P81080C48
IF9-2-10	GND	Power Amplifier	68P81080C48	IF9-2-10	GROUND	Synthesizer	68P81080C48
IF9-2-11	RF Input	Power Amplifier	68P81080C48	IF9-2-11	Tx Inj	Synthesizer	68P81080C48
IF9-3-1	PA TEMP	Power Amplifier	68P81080C48	IF9-3-1	PA Temp	Synthesizer	68P81080C48
IF9-3-2	PA_CNTL	Power Amplifier	68P81080C48	IF9-3-2	PA_CONTRL	Synthesizer	68P81080C48
IF9-3-3	Current Sense -	Power Amplifier	68P81080C48	IF9-3-3	Current_Sense-	Synthesizer	68P81080C48
IF9-3-4	Current Sense +	Power Amplifier	68P81080C48	IF9-3-4	Current_Sense+	Synthesizer	68P81080C48
IF9-3-5	A+	Power Amplifier	68P81080C48	IF9-3-5	A+	Synthesizer	68P81080C48
IF9-4-13	Not indicated	Power Amplifier	68P81080C48	IF9-4-13	Not Indicated	Synthesizer	68P81080C48
IF10-3-1	Not indicated	Power Amplifier	68P81080C48	IF10-3-1	Not Indicated	Receiver Front End	68P81080C48

# NOTES

Cut along dotted line

# SERVICE MANUAL QUESTIONNAIRE

We believe that reports from users provide valuable information for producing quality manuals. By taking a few moments to answer the following questions as they relate to this specific manual, you can take an active role in the continuing effort to ensure that our manuals contain the most accurate and complete information of benefit to you. Thank you for your cooperation.

In reference to Manual Number: 68P81080C48-C

## MCS 2000™ Mobile Radio

1. Please check all the appropriate boxes:

	Complete	Incomplete	Correct	Incorrect	Clear	Confusing	Size Adequate	Size Too Small	Not Covered in This Manual
Disassembly Procedures									
Alignment Procedures									
Exploded Views									
Schematic Diagrams									
Circuit Board Details									
Electrical Parts Lists									
Exploded View Parts List									

2. How would you rate the overall organization of this manual?

- excellent   
 very good   
 good   
 fair   
 poor

3. Did this Service manual provide you with the information necessary to service and maintain the specific equipment?

- very much so   
 generally yes   
 to some extent   
 no

4. How do you rate this particular Service Manual?

- excellent   
 very good   
 good   
 fair   
 poor

5. We would appreciate any corrections or recommendations for improving this manual. Please include the specific page number(s) of the diagram or procedure in question.

- a. Disassembly Procedures:(Page No. \_\_\_\_\_ )  
b. Alignment Procedures:(Page No. \_\_\_\_\_ )  
c. Exploded Views:(Page No. \_\_\_\_\_ )

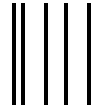

NO POSTAGE  
NECESSARY  
IF MAILED  
IN THE  
UNITED STATES

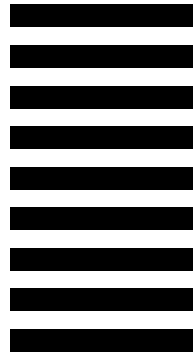

**BUSINESS REPLY MAIL**  
FIRST CLASS MAIL PERMIT NO 9040 FT. LAUDERDALE, FL

POSTAGE WILL BE PAID BY ADDRESSEE



**MOTOROLA**

Attention: Media and Communication  
8000 W. Sunrise Boulevard  
Ft. Lauderdale, FL 33322



FOLD

FOLD

(Continued)

Please specify the page number along with any corrections or recommendations for improvement.

- d. Schematic Diagrams: (Page No. \_\_\_\_\_ )
- e. Component Location Details: (Page No. \_\_\_\_\_ )
- f. Electrical Parts List: (Page No. \_\_\_\_\_ )
- g. Exploded View Parts List: (Page No. \_\_\_\_\_ )

6. General comments/suggestions:

Name:.....

Company:.....

Customer      COSC      MSS      FTR      Other

Address: .....

City/State/Zip:.....

Phone Number (Please include Area Code): .....

PLEASE USE TAPE TO SEAL

POSTAL REGULATIONS PROHIBIT USE OF STAPLES

# REPLACEMENT PARTS ORDERING

## ORDERING INFORMATION

When ordering replacement parts or equipment information, the complete identification number should be included. This applies to all components, kits, and chassis. If the component part number is not known, the order should include the number of the chassis or kit of which it is a part, and sufficient description of the desired component to identify it.

Crystal and channel element orders should specify the crystal or channel element type number, crystal and carrier frequency, and the model number in which the part is used.

## MAIL ORDERS

### Send written orders to the following addresses:

Replacement Parts/  
Test Equipment/Manuals/  
Crystal Service Items:

Motorola Inc.  
United States and Canada  
Accessories and Aftermarket  
Division  
Attention: Order Processing  
1313 E. Algonquin Road  
Schaumburg, IL 60196

Federal Government Orders:

Motorola Inc.  
United States and Canada  
Accessories and Aftermarket  
Division  
Attention: Order Processing  
7230 Parkway Drive  
Landover, MD 21076

International Orders:

Motorola Inc.  
United States and Canada  
Accessories and Aftermarket  
Division  
Attention: International Order  
Processing  
1313 E. Algonquin Road  
Schaumburg, IL 60196

## TELEPHONE ORDERS

United States and Canada Accessories and Aftermarket Division:  
Call: 1-800-422-4210  
1-800-826-1913 (For Federal Government Orders)  
1-847-538-8023 (International Orders)

Servicers Training (VHS Video Tapes):  
Call: 847-576-2828

## FAX ORDERS

United States and Canada Accessories and Aftermarket Division:  
FAX: 847-538-8198 (Domestic)  
847-576-3023 (International)  
Parts ID: 847-538-8194

Federal Government Orders:  
FAX: 410-712-4991  
International: 410-712-6200

## PARTS CUSTOMER SERVICE

United States and Canada Accessories and  
Aftermarket Division:  
Call: 1-800-422-4210  
Parts Identification:  
Call: 847-538-0021

## PRODUCT CUSTOMER SERVICE

Customer Response Center  
(Sales and Service Assistance):  
Call: 1-800-247-2346  
FAX: 1-800-232-9272

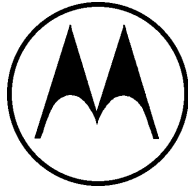

**MOTOROLA**

MCS 2000 Mobile Radio Service Instructions  
VHF Frequency Range, 25W Specific  
Publication Number 68P81080C48-O



6881080C48-O